

trotec

SpeedMarker 700 FL

Operating manual



8041

OM 8041_1.2_EN (01/2022)
ENGLISH (Translation)

/ SETTING NEW STANDARDS

(AT)

Trotec Laser GmbH

☎ +43 7242 239-7070
service-at@troteclaser.com

(CA)

Trotec Laser Canada

☎ +1 800 663 1149-902
techsupport@troteclaser.ca

(DE)

Trotec Laser Deutschland GmbH

☎ +49 89 322 99 65-13
service-de@troteclaser.com

(GB)

Trotec Laser UK

☎ +44 0191 4188 110
service-uk@troteclaser.com

(MX)

High Speed Laser Systems S. de R.L. de C.V.

☎ +52 55 5351-7252
mexico@troteclaser.com

(US)

Trotec Laser Inc.

☎ +1 866 226 8505, Option 2
support@troteclaser.com

(AU)

Trotec Laser Pty Ltd

☎ +61 26413-5904
service@troteclaser.com.au

(CH)

Trotec Laser AG

☎ +41 32387-1611
service-ch@troteclaser.com
suisse@troteclaser.com

(ES)

Trotec Laser España

☎ +34 93 102 50 50
soporte@troteclaser.com

(IT)

Trotec Laser Srl

☎ +39 02 9475 5447
supporto.tecnico@troteclaser.com

(NL)

Trotec Laser B.V.

☎ +31 850 70 51 55
support@troteclaser.nl

(ZA)

Rubber Stamp & Engraving

☎ +27 875 509-335
support@trodat.co.za

(BE)

**Trotec Laser België
Trotec Laser Belgique**

☎ +31 850 70 51 55
support@troteclaser.nl

(CN)

Trotec Laser GmbH

☎ +86 189 500 735 62
china@troteclaser.com

(FR)

Trotec Laser France SAS

☎ +33 1 72 62 20 94
techsupport.fr@troteclaser.com

(JA)

Trotec Laser Japan Corporation

☎ Tokyo: +81 42 313 0740
☎ Osaka: +81 6 6180 2200
service-jp@troteclaser.com

(PL)

Trodat Polska Sp. z o.o.

☎ +48 22 339 35 39
serwis_pl@trodat.net

Trotec Laser (XIAMEN) CO., LTD.

#5 GuAn Road South, MaXiang
Town
XiangAn District, XiaMen, China

Trotec Laser GmbH

FreilingerstraÙe 99
4614 Marchtrenk, Austria

General contact to Technical Support:

Tel.: +43 7242 239-7000

E-mail: techsupport@troteclaser.com

WWW.TROTECLASER.COM

Technical Changes	Technical specifications are subject to change without notice. Trotec Laser GmbH reserves the right to improve or modify any of the products without prior notice.
© Copyright	This documentation with all illustrations is intellectual property of Trotec Laser GmbH. The entire documentation is given to the user for personal use only. Reproduction, translation or any distribution to third parties is not permitted without the prior consent of Trotec Laser GmbH. Any breach of law will be prosecuted.

Content

1	Introduction.....	8
2	General Information.....	9
2.1	Information about this manual.....	9
2.1.1	Information about this manual.....	9
2.1.2	Storage of the manual.....	9
2.1.3	General instructions for using the manual.....	9
2.2	Explanation of symbols.....	10
2.3	Liability and warranty.....	11
2.4	Scope of delivery (standard configuration).....	11
2.5	Type plate.....	12
3	Safety.....	13
3.1	General safety notes.....	13
3.1.1	Intended use.....	14
3.1.2	Improper use.....	14
3.1.3	Residual risk.....	14
3.1.4	Machine modification.....	14
3.1.5	Operating modes.....	15
3.1.6	Applicable safety regulations.....	15
3.2	Laser safety.....	16
3.2.1	Laser classification.....	16
3.3	Areas of responsibility.....	17
3.3.1	Responsibilities of the operating company.....	17
3.3.2	Responsibilities of the operating personnel.....	18
3.4	Requirements for operating an service personnel.....	19
3.5	Machine identification (warning and safety stickers).....	19
3.6	Secondary (indirect) hazards.....	21
3.6.1	Fire hazard.....	21
3.6.2	Gases, fumes and dust.....	21
3.7	In case of emergency.....	22
4	Technical Data.....	23
4.1	Electrical requirements of the machine.....	23
4.2	Exhaust system requirements.....	23
5	Machine overview.....	26
5.1	General overview.....	26
5.2	Processing area.....	27
5.2.1	Software controlled z- and x-axis.....	29

Content

5.2.2	Software controlled z-, x- and y-axis.....	30
5.3.1	System control.....	30
5.3.2	Laser rack.....	31
5.3.3	Industrial PC.....	32
5.3	Safety devices.....	32
6	Before commissioning.....	35
7	Transport and Storage.....	36
7.1	Transport conditions.....	36
7.2	Storage conditions.....	36
7.3	Place of storage.....	36
7.4	Transport inspection and reporting of defects.....	37
8	Setup and installation.....	38
8.1	For your safety.....	38
8.2	Temperature and humidity.....	38
8.3	Installation location.....	38
8.4	Unpacking the system.....	39
8.5	Mechanical installation.....	40
8.6	Electrical installation.....	41
8.6.1	Overview laser rack interface (back side).....	41
8.6.2	Overview PC interface (back side).....	45
8.6.3	Mains connection.....	45
8.6.4	Interface pin configuration.....	46
9	Operation.....	48
9.1	Installation inspection.....	48
9.2	Marking software.....	48
9.3	Control elements.....	49
9.3.1	Manual operation.....	51
9.4	Power On/Off.....	52
9.5	Automatic mode.....	52
9.6	Emission indicator.....	53
9.7	Focusing.....	54
9.8	Options.....	55
9.8.1	SpeedMarker "DS" Dynamic Shifting.....	55
9.8.2	3D-Projection/Virtual Rotary.....	56
9.8.3	SpeedMark Vision - Smart Adjust.....	56
10	Ingetration / Connection.....	57
10.1	Switching sequences.....	57
11	Maintenance.....	59
11.1	Safety notes.....	59

11.2	Changing of the laser source filter mat.....	59
11.3	Cleaning the optics.....	60
12	Troubleshooting.....	61
12.1	Error, cause and remedy.....	61
12.2	Possible error messages.....	62
13	Contact details.....	64
14	Disassembly.....	65
15	Disposal.....	66
16	Appendix.....	67
16.1	CE 8041 SpeedMarker 700.....	68
16.2	Datasheet 8041 SpeedMarker 700.....	69
16.3	Datasheet Smart Adjust.....	80

1 Introduction

The SpeedMarker 700 fiber is a second generation of a high quality marking laser. The Yb fiber laser source means the system has an extremely long life cycle and minimal maintenance costs.

The combination of a high quality galvanometer scanner and a fiber laser produce highly precise marking results in short marking times.

This, together with the marking software and the available interfaces, provides a flexible and productive marking solution of the highest quality standards.

2 General Information

For the sake of readability, gender-neutral endings are not used in this operation manual. It is hereby expressly stated that all parts of the text where natural persons or groups of persons are mentioned refer to people of all genders.

2.1 Information about this manual

2.1.1 Information about this manual

**Before beginning any work on the machine, read this manual completely and carefully.
Keep the manual for further consultation close to the machine.**

This manual describes how to operate the machine properly and safely. Be sure to follow the safety instructions given here, as well as any local accident prevention regulations and general safety regulations applicable to the field of usage. Before beginning any work on the machine, ensure that the manual, in particular the chapter entitled "Safety Information" and the respective safety guidelines, has been read in its entirety and fully understood.



Information

Supplementary documentation can be found on the supplied storage medium. You can also request this from the manufacturer.

2.1.2 Storage of the manual

This manual is an integral part of the machine and must therefore be kept in its immediate vicinity and be accessible at all times.

2.1.3 General instructions for using the manual

The operating manual describes how to handle the device correctly and safely and guides you through the necessary steps for initial use. The operating manual also contains important information regarding system maintenance.



Warning

This operating manual must be read and followed carefully before commissioning and operating the device. Failing to observe individual points listed in this operating manual may result in personal injury and/or material damage to property!

General Information

This system may only be operated using devices and spare parts included in the scope of supply or the replacement or list of spare parts.

Ancillary devices must be calibrated to meet the safety and operational requirements of the base machine (please contact your dealer or the manufacturer with any queries).

2.2 Explanation of symbols

Important technical safety notes and instructions in this manual are indicated by symbols. It is important to observe and follow these notes and instructions on workplace safety. Avoid accidents, personal injury and material damage to property by acting with extreme caution.



Danger

This symbol indicates an imminently hazardous situation which, if not avoided, will result in death or serious injury.



Warning

This symbol indicates a potentially hazardous situation which, if not avoided, could result in death or serious injury.



Warning Current

This symbol warns of potentially dangerous situations related to the electric voltage. Failure to observe the safety instructions leads to risk of serious injury or death. Particular care should be taken during maintenance and repair work.



Warning Laser

This symbol warns of potentially dangerous situations related to the laser beam. Failure to observe the safety instructions leads to risk of serious injury.



Caution

This symbol indicates a potentially hazardous situation which, if not avoided, could result in minor or moderate injury.



Notice

This symbol indicates potential risks of damage to the supported product (or to property).

In addition, non-observance may result in damage, malfunction or failure of the machine.



Information

This symbol indicates tips and information which must be observed for efficient and trouble-free handling of the product.



Disposal

This symbol indicates notes regarding the professional disposal of the product or accessories.

2.3 Liability and warranty

Warranty periods specified in the manufacturers "warranty terms and conditions" shall be binding for the buyer. If no warranty periods are specified, the general terms and conditions of sale, delivery and payment apply.

All information, illustrations, tables, specifications and diagrams contained in this operating manual have been carefully compiled according to the current state of technology. No liability is accepted with regard to errors, missing information and any resulting damage or consequential loss.

Strict compliance with the safety procedures described in this operating manual and extreme caution when using the equipment are essential for avoiding and reducing the possibility of personal injury or damage to the equipment. The manufacturer shall not be liable for any damage and or faults resulting from nonobservance of instructions in this manual.

Nonobservance of the operation, maintenance and service instructions described within this manual absolves Trotec Laser GmbH from any liability in case of a defect.

Furthermore, Trotec Laser GmbH shall accept no liability whatsoever for damage caused by the use of non-original parts and accessories.

Additionally, Trotec Laser GmbH shall not be held responsible for any personal injury or property damage, of an indirect or specific nature, consequential loss, loss of commercial profits, interruption to business, or loss of commercial information resulting from use of the equipment described in this manual.

It is strictly prohibited to make any alterations, to prepare translations, decompile, disassemble, reverse engineer or copy the software.

Trotec Laser GmbH reserves the right to update any of the information, illustrations, tables, specifications and diagrams contained in this operating manual with regard to technical developments at any time without notice.

2.4 Scope of delivery (standard configuration)

- SpeedMarker 700
- Software and manuals on storage medium
- Lens cleaning tissues
- Allen key set
- Key for Rack
- Key for PC
- Key for Workstation
- PC Recovery Stick
- Exhaust connection cable (optional)
- Accessories SpeedMark Vision (optional)
- Power Cord
- Monitor, keyboard, mouse



Notice

The system should be returned and transported in the original packaging.

2.5 Type plate

The type plate contains information regarding the serial number, manufacturer, date of manufacture, connection values and consumption data.

The type plate is located on the reverse side of the laser rack.

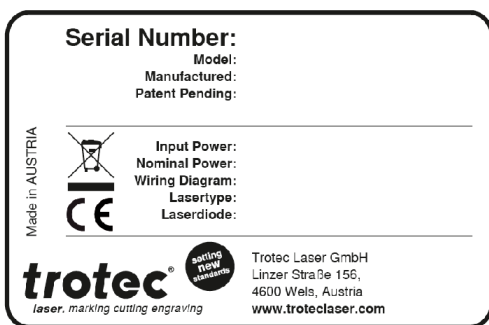
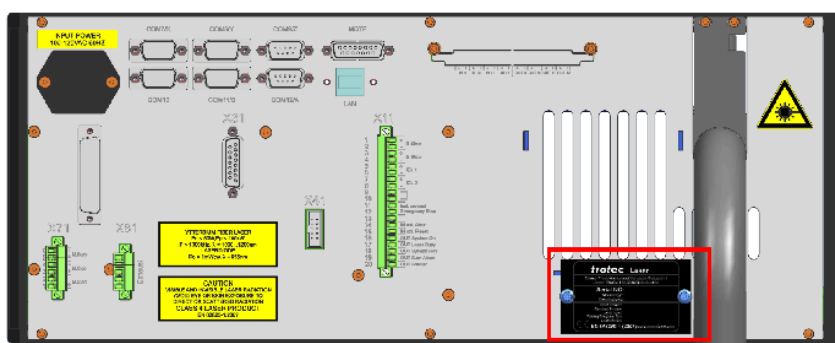

Enter the serial number, model and year of construction of the machine here.

This data is important should the unit experience a fault and for ordering replacement parts.

Serial number:	
Model:	
Year of manufacture:	

3 Safety

TO AVOID POSSIBLE HARM READ AND FOLLOW THESE INSTRUCTIONS.

The machine is built at the time of its development and production according to applicable, established technical rules and is considered to be safe to operate.

Dangers can be caused by the machine if the machine:

- is operated by unqualified personnel,
- the personnel have not been trained,
- the machine is used improperly or not as intended,
- or if the machine is used for other intended purposes.

This chapter provides an overview of all important safety aspects that are necessary for optimum protection of persons and safe and trouble-free operation of the machine. Other chapters of this manual contain specific safety notes for the avoidance and prevention of hazards.

3.1 General safety notes

GENERAL SAFETY NOTES:

- Only trained persons may perform activities on the machine.
- Safety devices, protective devices and machine parts must be present and must not be bridged. Faultless and intended function must be ensured.
- Work and control of the machine only by persons with sufficient knowledge of the function of the machine (applies especially to service operation).
- Never leave the machine unattended during operation. When the machine is not in use, turn off the main switch.
- Replace detached or damaged machine signage immediately.
- In the event of an unmanageable malfunction, switch off the machine and contact technical support in order not to damage the machine.
- The use of inferior spare parts or third-party components impairs the safety of the machine and renders the declaration of conformity (CE) supplied invalid.
- Protective equipment:
Wear suitable work clothing and protective goggles matched to the laser (laser class 4).
- Exhaust system:
Use suitable extraction equipment, as gases, fumes and other partially toxic by-products may be generated.
- Materials:
Select suitable parameters for the corresponding material. Safely extract dusts so that no detectable residues or residues can collect in the work area.

3.1.1 Intended use

The SpeedMarker 700 FL is a Class 2 laser marker as per DIN EN 60825-1 "Safety of laser products". It is intended for integration in systems and lines.

The product is intended exclusively for laser marking using the supplied marking software.

The following points should also be observed as part of the intended use:



Notice

- Only mark approved materials using suitable parameters.
- Perform maintenance and service according to the specifications in this operating manual.
- Use a suitable extraction system to remove fumes, dust or other reaction products.
- The machine may only be operated by suitably trained individuals.
- Observe effective safety regulations and the procedures described in this operating manual.

If the intention is to use the system for other applications, Trotec Laser GmbH should be informed in advance.

3.1.2 Improper use

Use of the machine for any purposes other than those intended or described in the present manual is regarded as improper and therefore prohibited. Trotec Laser GmbH will not accept any liability for damage caused by improper use. The operator is solely liable for all damages caused by improper use.

Non-observance of the operation, maintenance and service instructions described within this manual absolves Trotec from any liability in case of a defect.

3.1.3 Residual risk

Even if all safety regulations are observed, a residual risk remains when operating the machine.

3.1.4 Machine modification

It is strictly prohibited to alter, refit or modify the machine in any way without the express consent of the manufacturer.

Likewise, it is strictly prohibited to remove, bridge or bypass any safety devices. Operating conditions and connection and setup values stated in the data sheet must be complied with at all times.

Operation of the system is permitted only with original parts and accessories by the manufacturer. Use of third-party parts affects machine safety.

3.1.5 Operating modes

NORMAL OPERATION

For normal operation the following conditions must be met:

- Intended use of the machine (see chapter "Intended use").
- Operation of the machine only by trained personnel.
- Full functional and mounted safety devices.
- Machine must be in technically flawless condition.
- Processing of permissible materials according to the material list.
- Maintenance and service are not included.



Notice

During normal operation it is not necessary to wear safety glasses.

SERVICE OPERATION

Service activities may be carried out only by authorized, trained service technicians. If side panels as well as covers get removed and safety devices get bypassed, it can lead to direct and indirect scattered radiation. The service operation is therefore declared as laser class 4 (US: class IV) and proper precautions need to be taken (see "Laser classification").

3.1.6 Applicable safety regulations

The following directives and guidelines must be observed to avoid hazards when operating Trotec laser systems:

GUIDELINES/REGULATIONS

2006/42/EC	EC Machinery Directive
2014/30/EU	EMC Guideline

APPLIED HARMONIZED STANDARDS

EN ISO 12100:2011-03	Safety of machinery - General principles for design - Risk assessment and risk reduction.
IEC 60825-1:2014, EN 60825-4:2011	Safety of laser products - Part 1: Equipment classification and requirements.
IEC 60204-1:2005	Safety of machinery - Electrical equipment of machines - Part 1: General requirements.
ISO/DIS 11553-1:2009-03	Safety of machinery - Laser processing machines - Part 1: General safety requirements.
IEC 61000-6-4:2007-02	Electromagnetic compatibility (EMC) - Part 6-4: Generic standards - Emission standard for industrial environments.
ISO 13857:2008	Safety of machinery - Safety distances to prevent hazard zones being reached by upper and lower limbs.



Notice

Safety norms and regulations.

The general guidelines and directives listed within this manual may differ according to locality, region or country.

Therefore, always observe the directives as well as the regulations of the institutions for statutory accident insurance association applicable to you. The operator is responsible for fulfilling all safety requirements, as Trotec Laser GmbH has no influence on the proper use of the machine.

Observe the official regulations for your business location in accordance with the applicable local legal regulations (on accident prevention regulations or employee protection), e.g. DGUV regulation 11 for Germany.

3.2 Laser safety

3.2.1 Laser classification

The laser safety class indicates the risk potential based on the level of accessible laser radiation.

The SpeedMarker 700 FL is a laser class 2 product and complies to the latest safety norms and regulations (IEC 60825-1).

Class 1

The accessible laser radiation of Class 1 laser systems does not pose any hazard for the skin or eyes.

In order to operate as a Class 1 laser system, the following points must be observed:



Notice

- The entire course of the laser beam should be shielded to prevent radiation.
- Any covers providing access to laser areas which may be removed without using a tool should be fitted with suitable safety latches.
- Inspection windows in the housing should be fitted with safety glass suitable for the laser output and the shaft length of the laser (DIN EN 207).

The product uses a Class 2 pilot laser. In order to prevent irritation of the eyes during operation, the operator should not look directly at the laser source. Diffuse reflections of the pilot laser are entirely harmless.

Class 2 (US: class II)

The accessible laser radiation of Class 2 (US: Class II) laser systems does not pose any hazard for the skin. Diffuse reflections as well as any short-term irradiation of the eyes (exposure time max. 0.25 seconds) also pose no risk due to the low output power.

However, it is possible to suppress the natural eyelid closure reflex and stare into the class-2 laser beam for a time long enough for the eyes to get injured.

Class 4 (US: class IV)

Class 4 (US: class IV) high powered lasers (visible or invisible) considered to present potential acute hazard to the eye and skin for both direct and scatter (diffused) conditions.

Also have potential hazard considerations for fire (ignition) and byproduct emissions from target or process materials. It is the responsibility of the operator of the machine to take appropriate measurements to eliminate any dangers such as fire or explosions through the laser beam.



Warning Laser

Obligations of the operator for the operation of class 4 lasers (US: class IV):

- Observe official regulations for the business location in accordance with the applicable local legal regulations (on accident prevention regulations or employee protection), e. g. DGUV regulation 11 for Germany.
- According to DGUV regulation 11 "Laser radiation", as well as national regulations:
Written appointment of a competent laser safety officer for compliance with the relevant regulations.
- Mark the danger zone as such by attaching warning lights and warning signs on the outside.
- Protect the danger zone against unauthorized access.
- Wear appropriate laser safety glasses within the danger zone that are matched to the wavelength and power of the laser.
- Install an additional and well visible warning light to warn the operator of the presence of laser radiation.

Compliance with the points above does not absolve the operator from meeting the relevant standards and guidelines for the operation of a Class 4 laser system.

3.3 Areas of responsibility

3.3.1 Responsibilities of the operating company

The operator has the following responsibilities:

- It is the responsibility of the operator to comply with the national official and statutory regulations for the operation of a class 4 (US: class IV) laser system or laser system with a build in laser source of class 4 (US: class IV).
- In addition to the safety notes and instructions stated in this manual, consider and observe the local accident prevention regulations and general safety regulations that apply at the operation site of the machine.
- A CO₂ fire extinguisher must always be at hand, as the laser beam can ignite flammable materials.
- If the machine is used industrially, the operator is subject to the legal obligations concerning industrial safety.
- All personnel involved in installation, set-up, operation, maintenance and repair of the machine must have read and understood this manual and in particular the "Safety" section. The personnel must be trained and informed about all the functions, potential dangers and safety issues of the machine on a yearly basis.

- The user is recommended to prepare company internal instructions considering the occupational qualifications of the personnel employed in each case, and the receipt of the instruction/this manual or the participation in the introduction/training should in each case be acknowledged in writing.
- Keep the manual in the immediate vicinity of the machine so that it is accessible at all times to all persons working on or with the machine.
- Authority for the individual activities relating to the application of the machine (e.g. installation, operation, maintenance and cleaning) must be clearly defined and observed, so that no unclear competencies result under the aspect of safety. This applies in particular to work to be performed on the electrical equipment that may only be performed by qualified specialists.
- Maintenance and repair work as specified in the manual must be carried out regularly.
- For all activities concerning installation, set-up, start-up, operation, modifications of conditions and methods of operation, maintenance, inspection and repair, the switch-off procedures that may be provided in the manual must be observed.
- Provide appropriate personal protection equipment (e.g. protective goggles according to wavelength and laser power).
- The operator is responsible for the safety-related state of the machine.
- Do not store any flammable materials in the working area or in the immediate vicinity of the device. Particularly, residues of processed materials have to be removed to prevent any fire hazard.
- The operator must ensure cleanliness and accessibility at and around the machine by corresponding instructions and controls.

3.3.2 Responsibilities of the operating personnel

The operating personnel has the following responsibilities:

- Always wear personal protective equipment.
- It is the duty of the operating personnel to check the machine before start of work for externally visible damage and defects, and to immediately report any changes that appear (including behavior during operation) that may affect the safety of the machine. It must be made sure that the machine is operated only in perfect condition.
- The machine must not be left unattended while it is operating (supervised operation).
- Switch off the machine described herein at the main switch for periods of non-use.
- Operate the machine described here only with a lens in place. A missing lens may cause the unfocused laser beam to be reflected out of the housing.
- Stop this machine immediately in case of failure.
- No working methods are permitted that affect the safety of persons or of the machine.
- The machine and its components, such as the lens and mirrors, are to be kept clean at all times.



Caution

The adjustment of the beam path may only be carried out by service personnel of Trotec Laser GmbH.

3.4 Requirements for operating an service personnel

The requirements for the operating and service personnel are:

- The personnel must have read and understood this manual and in particular the "Safety" section.
- The personnel must not be under the influence of drugs, alcohol or reactivity affecting medication when working on or with the machine.
- The personnel must be familiar with using the CO₂ fire extinguisher.
- The personnel must be trained in order to be qualified to operate the machine. If the personnel lack the necessary knowledge for working on or with the machine, they must first be trained and note down the training in the training verification form.

Activity	Intended user group	Definition
Control/operation/other activities (e.g. troubleshooting, maintenance)	Qualified personnel or Trotec service technicians	Qualified personnel are those who can judge the work entrusted to them and detect potential risks based on their occupational training, knowledge and experience as well as their understanding of the relevant regulations.

3.5 Machine identification (warning and safety stickers)

The warning and information signs are attached to the device at those positions which could be a source of danger before commissioning or during operation. Therefore pay special attention to the information on the signs.



Caution

Lost or damaged warning and safety stickers.

If any warning and safety stickers are lost or damaged, the user is not able identify risks anymore, and there is danger of injury.

- Replace lost or damaged labels immediately.
- Contact your Trotec Laser GmbH dealer for details.

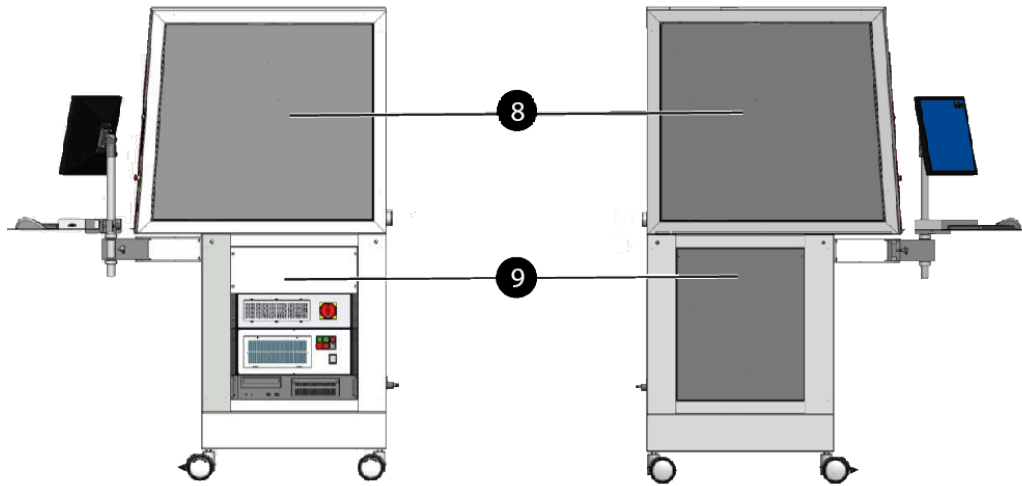
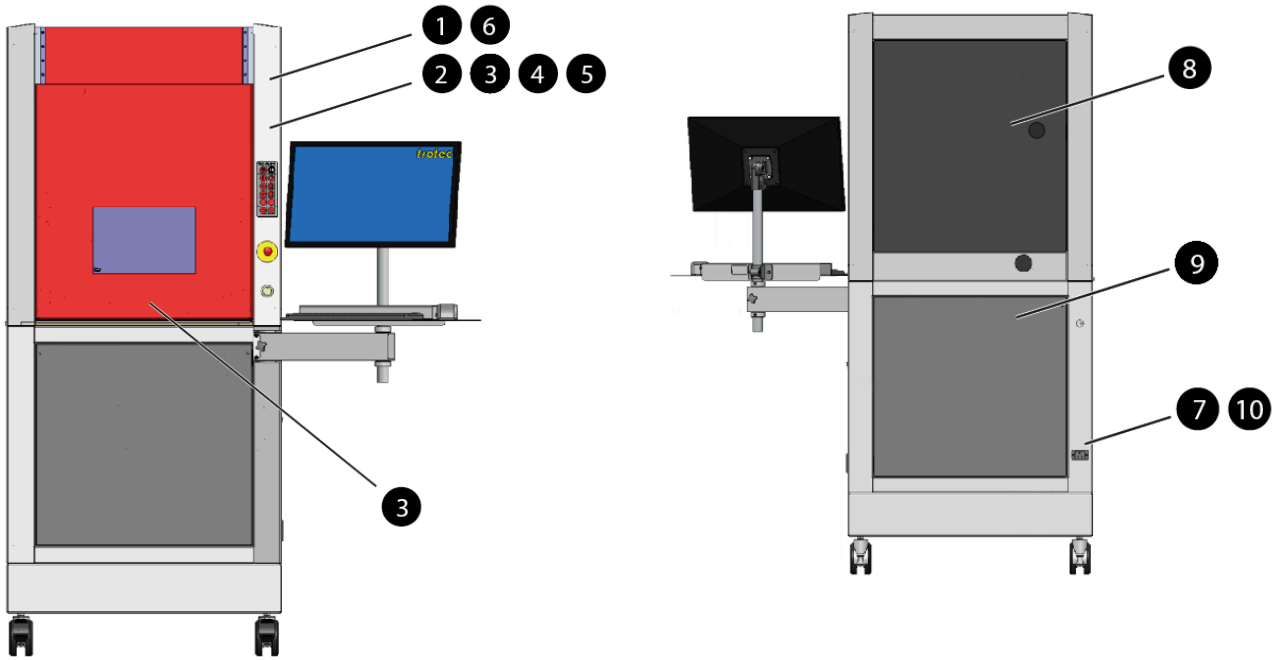

1



4

CAUTION
VISIBLE LASER RADIATION
CLASS 2, WHEN OPENED
DO NOT STARE INTO BEAM

7



10

INPUT POWER
230VAC 60Hz

2

Yb FIBER LASER:
 $P_p < 110 \text{ W}$, $P_r < 100 \text{ kW}$
 $E_p < 2 \text{ mJ}$
 $t = 1 - 1000 \text{ ns}$
 $F < 2 \text{ MHz}$
 $\lambda = 1055 \dots 1075 \text{ nm}$



5

NEVER OPERATE THE LASER SYSTEM
WITHOUT CONSTANT SUPERVISION
EXPOSURE TO THE LASER BEAM MAY
CAUSE IGNITION OF COMBUSTIBLE
MATERIALS WHICH CAN CAUSE SEVERE
DAMAGE TO THE EQUIPMENT

8

CAUTION
VISIBLE AND INVISIBLE LASER RADIATION
CLASS 4, WHEN OPENED
AVOID EYE OR SKIN EXPOSURE TO
DIRECT OR SCATTERED RADIATION



3.6 Secondary (indirect) hazards

3.6.1 Fire hazard



Warning

Fire hazard

Fire hazard from gas and processing of inflammable materials.

- Do not operate the device without supervision.
- Keep CO₂ fire extinguisher ready at hand in the immediate vicinity of the device.

If a main laser beam hits easily flammable material, e.g. paper, this may ignite and a fire can quickly occur. Therefore, before switching on the laser, you should make absolutely sure that there is no easily flammable material in the beam path.

Furthermore, gases that can form below the material to be processed may ignite. Especially if the extraction requirements are not met.

Inadequate care and cleaning of the system increases the risk of flame formation.

Regularly check your air cooling system on the laser. The function of the filters and fans in particular should be checked regularly so that defects caused by excess temperature are avoided.

3.6.2 Gases, fumes and dust

Depending on the materials being processed and the parameters selected, laser processing may generate gases, fumes, aerosols or dust. Depending on the material, such by-products may be toxic. In individual cases, the reaction products may be electrically conductive dusts. If these enter electric systems, short-circuiting with personal injury and property damage may occur.

The operator is responsible for ensuring presence of a suitable extraction system and compliance with the relevant guidelines in order to protect persons and the environment. The guideline VDI 2262 1-3 "Workplace air" provides, among other things, additional remarks.

The operator must also ensure that gases, fumes or dust do not settle on the processing lens. Any dirt accumulating on the processing lens can lead to loss of performance, poor processing results and damage to the device.

3.7 In case of emergency

WHAT TO DO IN THE EVENT OF MALFUNCTIONS

- In unusual operating conditions, open the lid to stop the machining process or, if available, press the emergency stop button and switch off the machine.
- If necessary, disconnect the machine from the main power supply.
- Inform the laser protection officer and your supervisor.
- Follow the instructions.
- Repair work must only be carried out by Trotec Laser GmbH service technicians.
- In the event of a fire: Fight the fire with a CO₂ fire extinguisher as far as is possible without risk.



Notice

After a deletion, Trotec Technical Support must be involved before the system is put back into operation.

WHAT TO DO IN THE EVENT OF AN ACCIDENT, FIRST AID

- If eye damage occurs due to laser radiation (if the MPD values are exceeded), the casualty must present to an ophthalmologist immediately.
- The assumption of eye damage is justified if radiation with laser beams has been used and the MPD values have been exceeded.
- First aiders must protect themselves.
- Switch off the machine.
- Rescue the injured person from the danger area and provide first aid.
- Call an emergency doctor!

4 Technical Data

→ The technical data sheet can be found in the appendix of this manual.

4.1 Electrical requirements of the machine



Caution

Inadequate or inappropriate power sources can lead to machine damage and are not covered by any liability.

Verify that the electrical outlet is capable of providing the proper voltage, frequency and amperage required by the laser machine described in this manual.



Caution

Electrical noise, unstable power supply as well as voltage spikes in power supply can cause interference and possible damage to the electronics of the laser machine.



Notice

Use an individual circuit for the laser machine and the PC and an individual circuit for the exhaust system. Install your computer to the same circuit as the laser machine to prevent electromagnetic interactions.

Furthermore it is highly recommended that you use a overvoltage protection switch to protect your computer equipment.

If electrical power fluctuations, brownouts or power outages are a problem in your area, an electrical line stabilizer, UPS (Uninterruptible Power Supply) or backup generator are required. When installing any of these devices, ensure that they meet the electrical requirements of the laser machine.

4.2 Exhaust system requirements



Danger

Danger of emission of toxic gases, vapors or dust.

During laser operation, toxic aerosols may be produced.

- The laser system may be operated only with properly installed and operating exhaust system.
- Check with the material manufacturer for its toxic effect.



Caution

The laser may only be operated with properly installed and operating exhaust system. Damage to the system, caused by the use of not any exhaust system or improper extraction equipment, will not be covered by any liability.

Technical Data

The requirements for the exhaust system and recommended Trotec exhaust systems for standard applications depend on the working table installed in the machine.



Notice

Connection has to be carried out by our Technical Support.

Observe instructions for operation and maintenance according to the operating manual of the exhaust system.

TECHNICAL DATA OF THE CORRESPONDING EXHAUST SYSTEMS:

Exhaust system	Hose connection \varnothing [mm] (inside diameter)	Volume flow [m ³ /h]	Pressure [Pa]
Atmos Nano	45	200	8500 (230V)
Atmos Cube (Atmos Compact)	80 / 80 (70 / 45)	250	8500 (230V) 5800 (115V)
Atmos Mono	70 / 70 / 45	320	8500 (230V) 5800 (115V)
Atmos Mono Plus	70 / 70 / 45	320	8500 (230V) 5800 (115V)
Atmos Duo Plus	70 / 70 / 45	(2x) 320	8500 (230V)
Vent Set 300	80	max. 1000	max. 2550
Vent Set 400	100	max. 1000	max. 3800
Vent Set 500	100	max. 1200	max. 7000

REQUIREMENTS FOR THE EXHAUST SYSTEM:

Machine	Volume flow [m ³ /h]	Pressure [Pa]
SpeedMarker	320	8500

The monitoring point for flow rate and pressure is at the exhaust port at the laser machine. Pressure loss by hoses / pipes or filter parts of the exhaust system has to be determined and additionally calculated when selecting a proper exhaust system.

A powerful exhaust system keeps the lifetime of optics and mechanical components, the cutting quality and the laser power interacting with the workpiece from being impaired by fumes and dust accumulating in the machine.



Notice

The exhaust power available for the application will be reduced by e. g. bends, small hose diameters and long hoses.

You should therefore note the following:

- Avoid bends.
- Keep hose as short as possible.
- Use hose diameters as large as possible.

Applications generating large amounts of dust or fumes may require a stronger exhaust system. Use of separate exhaust systems for head and table exhaust may also be necessary.

In this case it is absolute necessary to consult your distributor.

5 Machine overview

5.1 General overview

FRONT VIEW

SpeedMarker 700



SpeedMarker 700 RT



- 1 Laser safety glass (Observation window)
- 2 Safety door
- 3 Rolls (optional levelling feet)
- 4 Operating panel
- 5 Monitor, keyboard, computer mouse

- 6 Emergency stop button
- 7 Start button
- 8 Light grid
- 9 Partition panel
- 10 Rotary table

SIDE VIEW RIGHT OR LEFT

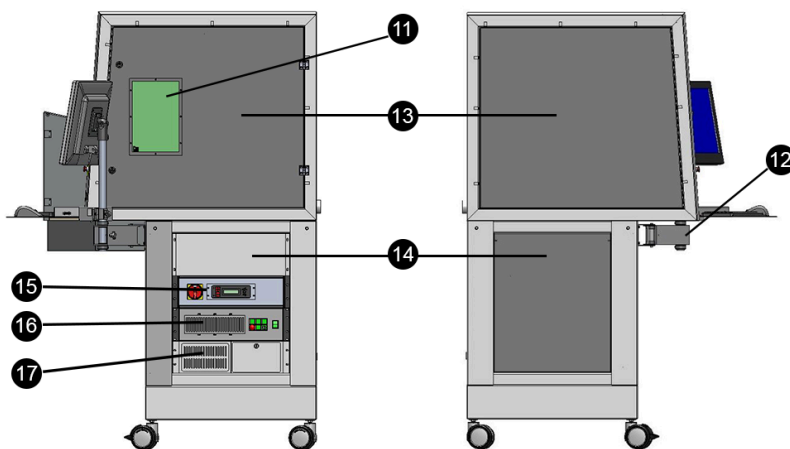

- 11 Viewing window (only for 700 RT)
- 12 Swivel arm for control panel
- 13 Protection cover
- 14 Bottom cover panel
- 15 Control rack
- 16 Laser rack
- 17 Industrial PC

BACK VIEW

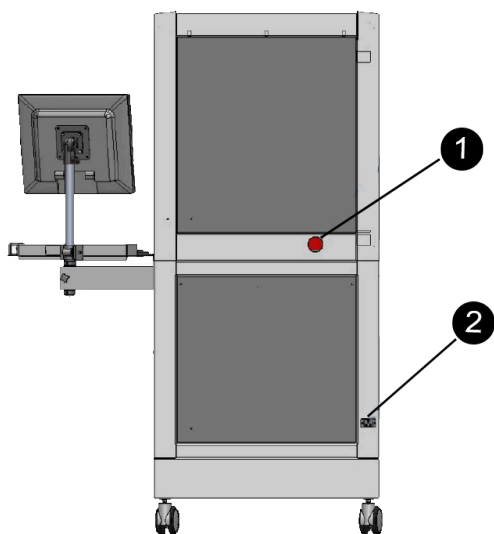

- 1 Connection Exhaust system
- 2 Connection Power supply

SUPPLY CONNECTIONS

The power cable can be connected via a power supply plug connection.

Connect a suction hose with nominal diameter 45.

5.2 Processing area

The processing area is closed during the laser process.

SpeedMarker 700

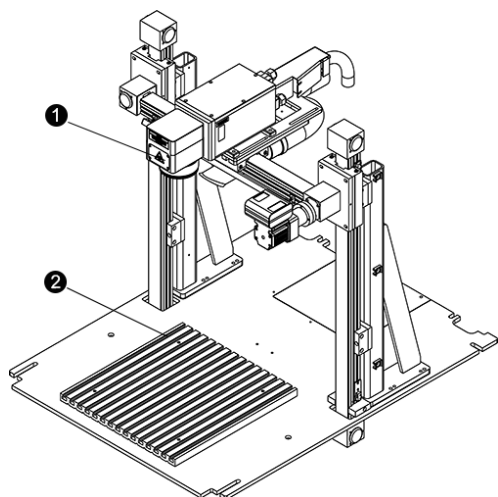

SpeedMarker 700 RT

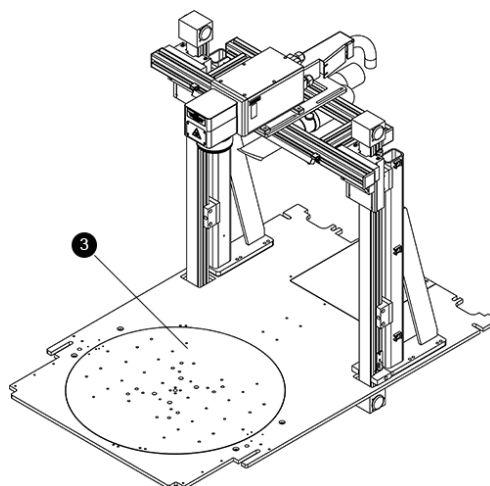

- 1 Laser head
- 2 T-slot plate
- 3 rotary plate

DRILLING PATTERN T-SLOT PLATE

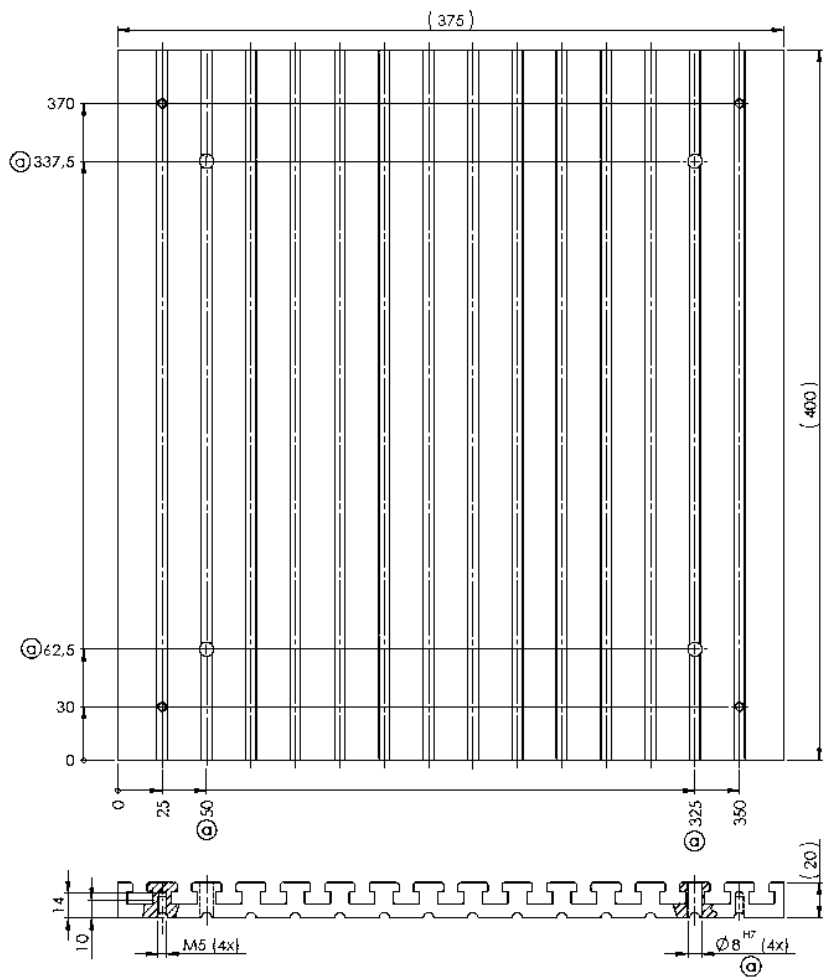

HOLE PATTERN REVOLVING TRANSFER TABLE

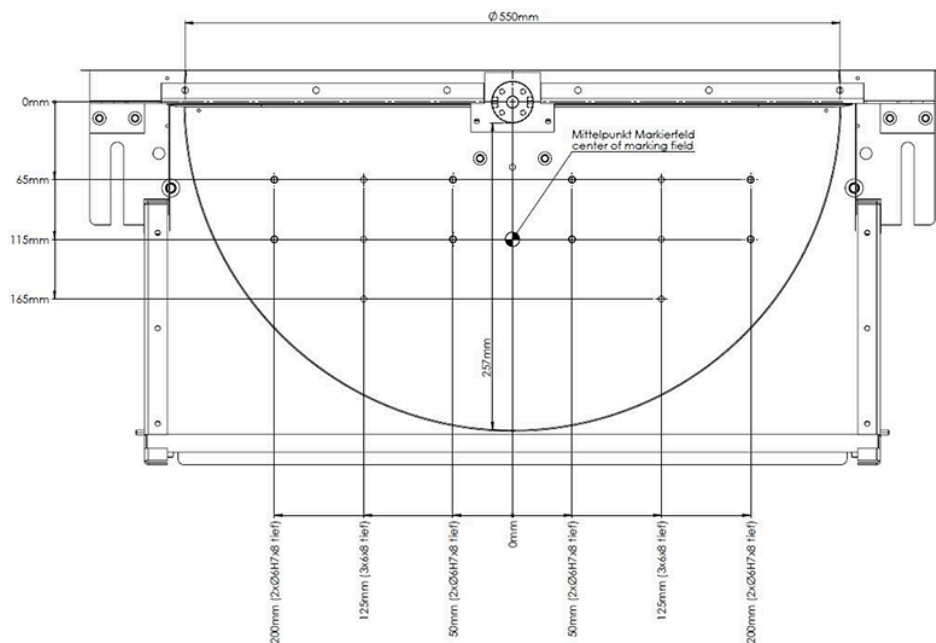

5.2.1 Software controlled z- and x-axis

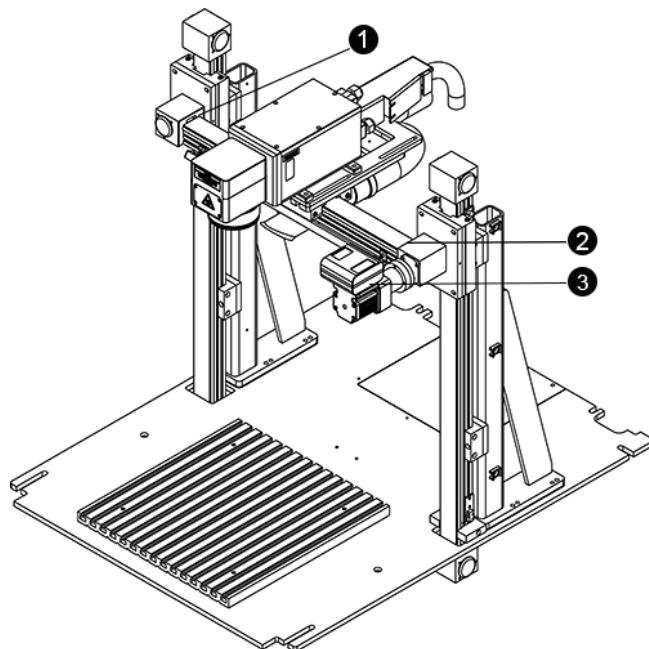

- 1 Limit switch left
- 2 Limit switch right
- 3 Axis drive

5.2.2 Software controlled z-, x- and y-axis

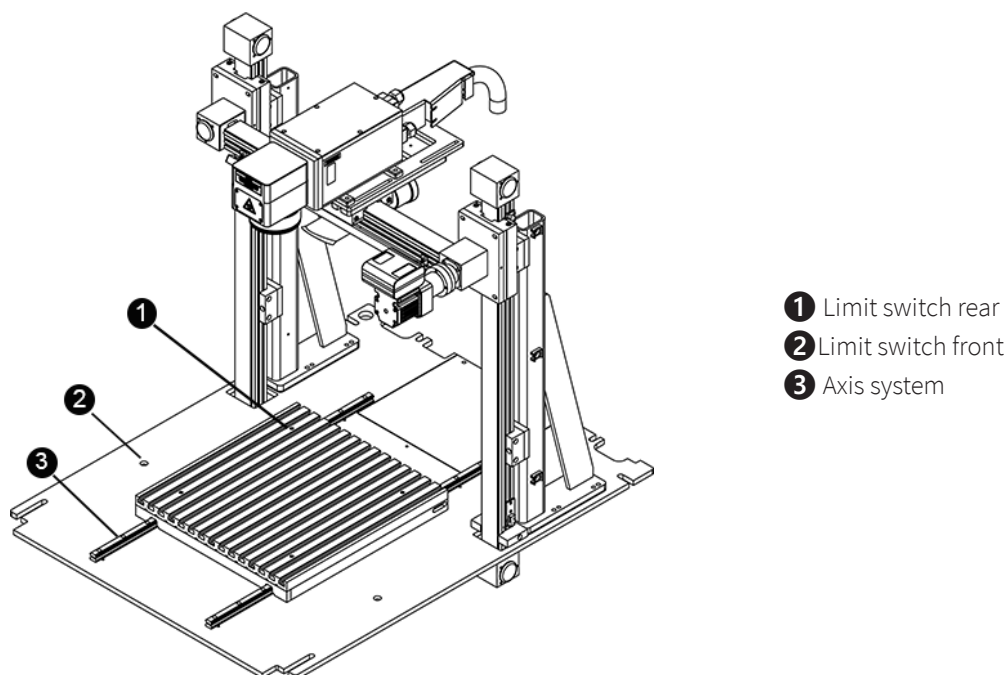

General structure of the axes

- Each axis system consists of a linear servo axis with high precision.
- The z and y axes are designed as a tandem axis.
- The laser head is mounted on the x-axis via an adapter plate, which in turn is mounted on the z-axis.
- The y-axis is a movable table on which the object to be marked is placed.
- Each of the three axes is limited by two limit switches and two mechanical stops.

The electrical and electronic controls are housed in three 19" racks:

- System control
- Laser control
- Industrial PC

5.3.1 System control

The system control takes over the control of the safety gate, the automatic sequence and the safety.

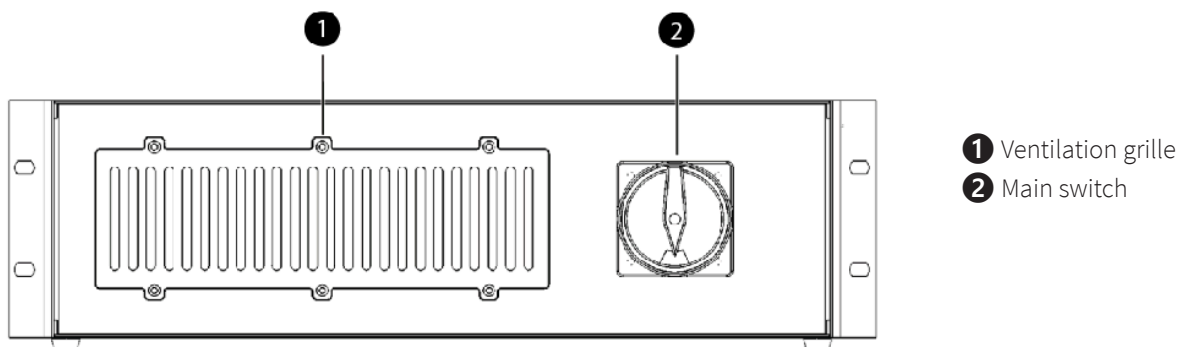

5.3.2 Laser rack

LASER RACK

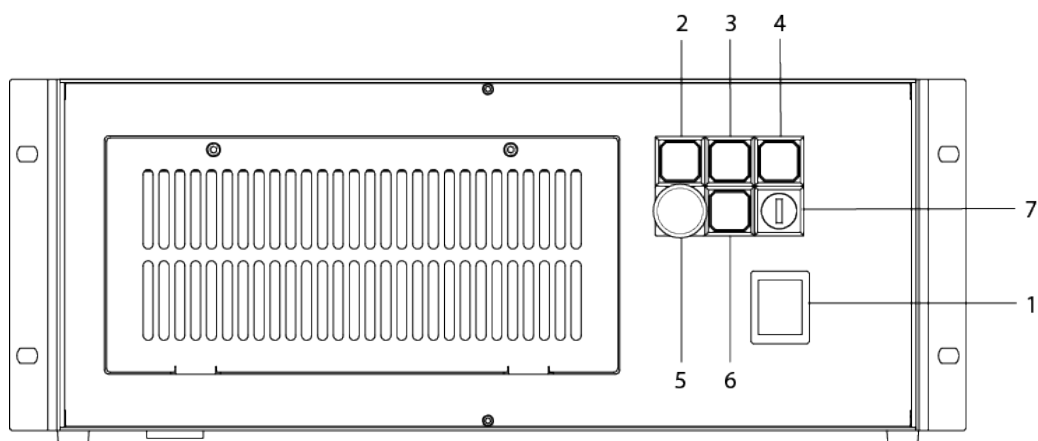

Number	Description	Types
1	Main switch	toggle switch
2	System ready	control lamp
3	Shutter	control lamp
4	Laser busy	control lamp
5	Emergency stop button	switch
6	Error reset	button
7	Key switch	switch

5.3.3 Industrial PC

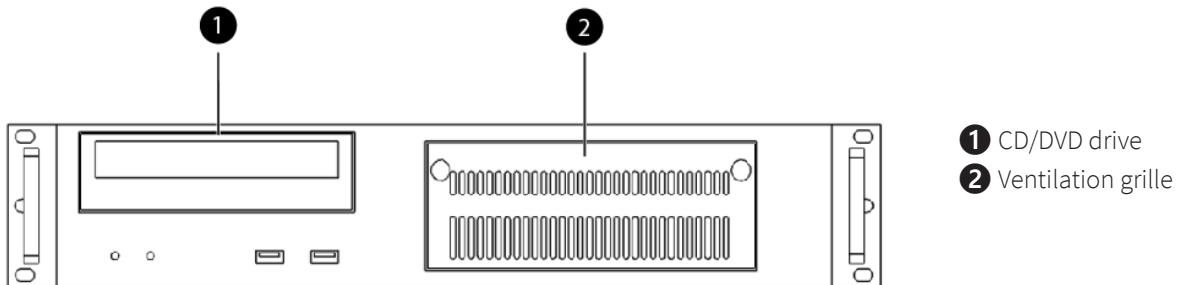

5.3 Safety devices

MAIN SWITCH

Base cover on the right:

- When the main switch is operated, the entire system is de-energized.
- Laser is off.

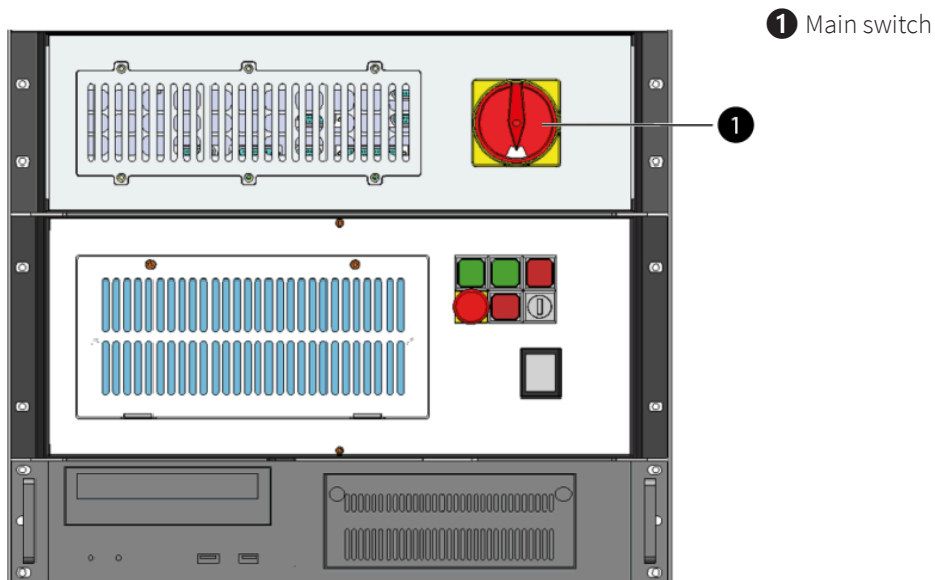

EMERGENCY STOP BUTTON

1. On the front.
2. On the laser rack.

Task of the emergency stop device:

First priority: prevention of danger to operating personnel.

Second priority: prevention of damage or destruction of machine or material.

- Immediately switch off the circuit.
- Laser beam is interrupted by the shutter.
- All movements are stopped.
- The triggering of the emergency stop function is indicated by a fault message.

EMERGENCY STOP ACKNOWLEDGMENT - SEQUENCE

Variant 1:



1. Unlock emergency stop button

Turn emergency stop button

2. Acknowledge emergency stop

Press the ON button on the keypad

3. Acknowledge laser fault

Confirm ON button on the keypad

Variant 2:

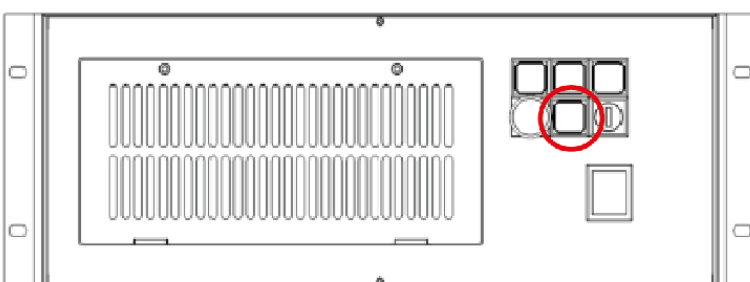

Press the error reset button on the laser rack.

SAFETY SWITCH ON THE SAFETY DOOR

Observation window:

The light blue observation window in the front door is made of a laser protection filter according to DIN EN 201, which is made of a special material that is adapted to the laser type and absorbs the laser radiation. If the window is damaged, it must be replaced.

Safety shutter in the laser:

If a safety circuit in the laser system is open, the safety shutter in the laser closes immediately. For safety reasons, this shutdown follows via safe components. This interruption in the laser is mechanical. An error message is output.

Cladding panels

6 Before commissioning

- Read the operating manual and ensure it is accessible at all times.
- The ambient temperature must be between +15 °C and +25 °C (59 °F and 77 °F) and not exceed the relative humidity of 45-65% (non-condensing). Non-observation leads to damage.
- A laser system consists of high quality electrical and optical components. Mechanical stresses, vibrations and impacts must always be avoided.
- If the system has been subject to significant temperature variations, it must be brought back to room temperature before being commissioned.
- Sufficient air must be supplied to the 19 inch module of ventilated systems. The accumulation of heat due to covered ventilation slots or filter pads can damage the system.
- Assemble the device at the point of installation according to the instructions.
- The operating personnel must read and understand the operating manual, in particular the chapter on “Safety notes”. It is recommended that the operator compiles with inhouse instructions regarding safety and operation and that the receipt of these instructions/operating manual and the participation in briefings/training courses is confirmed in writing.
- Laser marking may generate gases, fumes and other reaction products on the surface of the material. The operator must therefore use an effective extraction system.

7 Transport and Storage

7.1 Transport conditions

- When transporting outside, always transport in a covered vehicle or one with sufficient weather-proofing.
- Protect the machine against transportation damage using straps and inserts, and leave sufficient distance between other transported items.
- Ambient temperature for transportation:
minimum temperature 10°C
maximum temperature 40°C
- Handle the machine and machine components with care.
- Do not place any heavy loads on the machine or machine components.
- Avoid heavy impacts.
- Take particular care when transporting electronic components.

Transport conditions

Transport temperature (ambiente temperature):	-10 °C to +40 °C
Relative humidity:	Maximum 70%, non-condensing

- Avoid high temperature fluctuations.

7.2 Storage conditions

- Store the machine and machine components in a dry location.
- Protect the machine and machine components against scratches.
- Take particular care when packing away electronic components.
- When storing for a long period, preserve bare metal parts (e.g. apply oil).

Storage conditions

Storage temperature (ambiente temperature):	+0 °C bis +30 °C
Relative humidity:	Maximum 60%, non-condensing

- Avoid high temperature fluctuations.

7.3 Place of storage

Storage room or boxed with sufficient weatherproofing. The storage location must be free from corrosive elements, fumes and flammable materials.

7.4 Transport inspection and reporting of defects

- Immediately after receipt inspect the delivery to ensure that it is complete and has not suffered any damage.
- If any transport damage is visible, do not accept the delivery, or accept it only with reservation.
- Record the scope of the damage on the transport documents or delivery note.
- For all defects that are not discovered upon delivery, be sure to report them as soon as they are detected, since damage claims must be filed within a certain period, as mandated by law.

8 Setup and installation

8.1 For your safety



Notice

The setup has to be carried out by Technical Support.

8.2 Temperature and humidity

Ambiente conditions

Operating temperature (ambiente temperature):	+15 °C to +25 °C (59 °F to 77 °F)
Relative humidity:	45% to 65%, non-condensing

- If the system has been exposed to large temperature fluctuations, it must first be brought back to room temperature before commissioning.

ENVIRONMENTAL CONDITIONS

- Provide sufficient illumination at the workplace.
- Ensure a dust-free environment (II° according to IEC60947-1).
- Shielding from EMC.
- Freedom of interfering electrical installations, hoses and pipe lines.
- Power supply free of fluctuations.

8.3 Installation location

INSTALLATION LOCATION

The installation location must:

- Have a stable power supply.
- Be vibration free.
- Have sufficient air supply for the laser rack and PC.

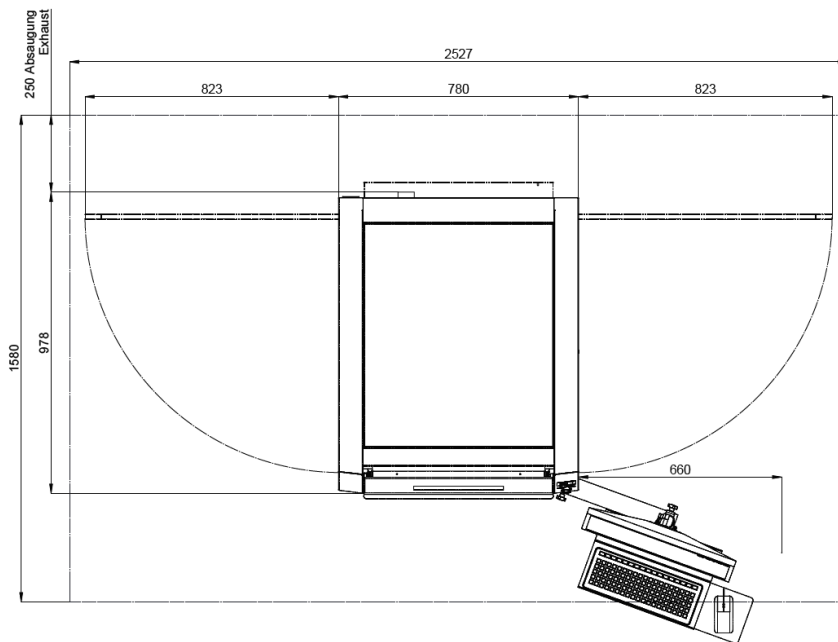

8.4 Unpacking the system

REMOVE TRANSPORT PROTECTION:



1. Push up the high safety door **1** slightly.
2. Remove the screw of the fairing **2** on the left side.
3. Open the cover..



Caution

Risk of crushing fingers!

If necessary, close the cover carefully, paying attention to your fingers.

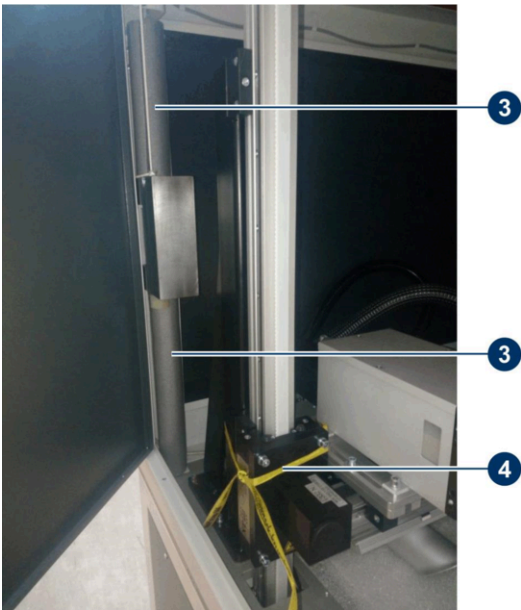

4. Remove foam fuses **3**.
5. If available, remove safety tape **4** at the galvo scanner.

8.5 Mechanical installation

The correct, stable and reproducible alignment of the working head in relation to the workpiece to be marked is a prerequisite for faultless marking results. The marking head should therefore be installed with appropriate care.

FIBER OPTIC CABLE

The working head is connected to the actual laser source in the laser rack via an approx. 2.9 m long fiber optic cable. The fiber optic cable is enclosed with the jumper cables in a black protective tube for protection. In order not to damage the filaments, do not bend the cable by a radius of more than 66 mm. The tube should also not be subject to any mechanical stresses.



Caution

If necessary, the cable and the fiber optic cable may be disconnected from the marking head. As this will expose sensitive optical surfaces, this may only be performed by trained service personnel.

LASER RACK AND PC

The laser rack and the PC should be located next to or directly above one another if possible in order for the modules to be connected to one another with the cables provided.

When installing in a control cabinet or rack, ensure there is sufficient ventilation. Both the laser rack and the PC require a sufficient supply of air. The air should be sucked in from the front and blown out at the rear. When installing the laser rack, also ensure the minimum radius of curvature of the fiber optic cable (black tube) is not exceeded on the rear side.

SOFTWARE INSTALLATION

The software will be installed by starting the SETUP.exe from the software-CD. Please follow the steps on the screen. The correct configurations files must be installed after the software setup is finished. The installation guide is enclosed in the accessory.

8.6 Electrical installation

Following the mechanical installation of the marking head, laser rack and PC, the components must be connected to one another electrically. (The laser rack and marking head are already connected to one another on delivery.) The peripherals (power supply, external control and safety signals, etc.) are then connected via the laser rack and PC interfaces.

All connectors are clearly identified in order to facilitate the electrical installation.

The connector denotations are also coded. The last digit of the connector denotation identifies the respective hardware components.

Therefore:

X ... 1 Laser rack

X ... 2 Marking head

8.6.1 Overview laser rack interface (back side)



Notice

Before the laser marker can be put into operation, the external safety circuits and the external start and stop signals must be connected.



Caution

When making these connections, the operator must ensure that all safety circuits comply with the respective valid national standards and guidelines for the use of laser devices. Otherwise the device may cause personal injury or material damage.

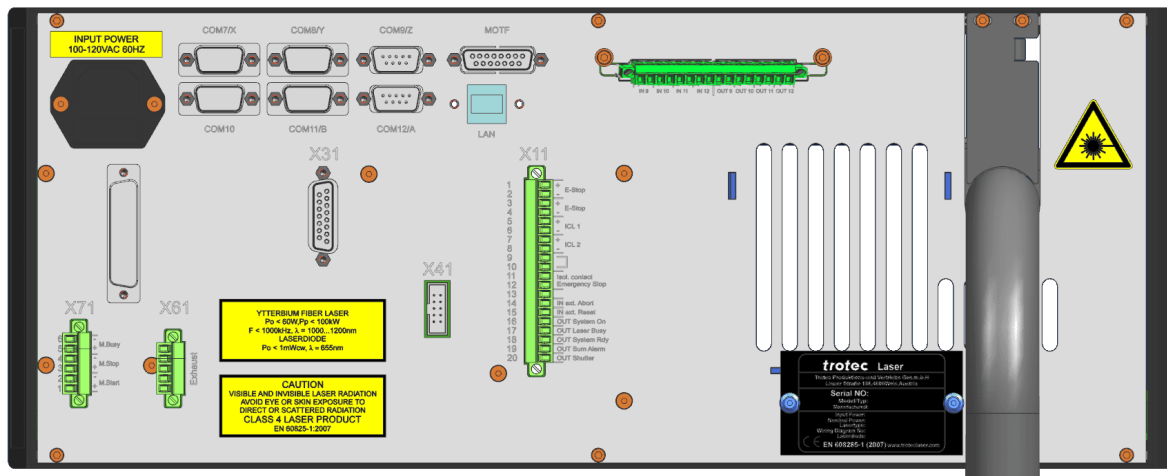

The following connectors are available on the laser rack:

X11 – Safety circuit (Emergency stop button / interlock safety switch / external messages)

The X11 connector enables the connection of external safety circuits, additional emergency stop circuits and external warning lamps.



Warning

The digital 24V inputs should only be controlled by isolated contacts with the 24V pin 13 on X11. The input of signals with any other reference potential could result in damage to the respective inputs.

X31 – External panel

The connector X31 may be used to connect an external control panel such as that located on the front of the laser rack. If no external panel is connected, the supplied connector must be used with the bridging devices.

X61 – Exhaust system

This connector is used to control, start and stop a Trotec extraction unit. Only use the original cable supplied.

X71 – Start / Stop

The X71 connector may be used to send start and stop signals via an external controller or receive a signal from the laser. The pin configuration is provided in "Interface Pin Configurations"

"Busy" is a laser output which can be set as required using a script.

"Stop" is an external input used to interrupt all running laser programs immediately. It is not necessary to monitor these inputs in a script.

"Start" is an external input which may be monitored in the software in order to trigger a marking process. If the monitoring of the signal is not active within a script, the input will have no effect on the program sequence.

For the "Start" and "Stop" Signal external 24VDC are needed.

COM7/X

Connection X-Axis

COM8/Y

Connection Y-Axis

COM9/Z

Connection Z-Axis

COM10

Reserved

COM11/B

Connection B-Axis

COM12/A

Connection A-Axis

LAN

Connection between PC and Laserrack



Warning

The maximum load of each of the digital 24V outputs on the interface is 100mA. A short circuit of the outputs must be avoided as it will damage the respective inputs.

The system is equipped with an additional Input/Output option.

With this option you can

- feed the software with e.g. start, stop or status signals.
- activate signals by the software for e.g. warning lamps or relays.

Setup and installation

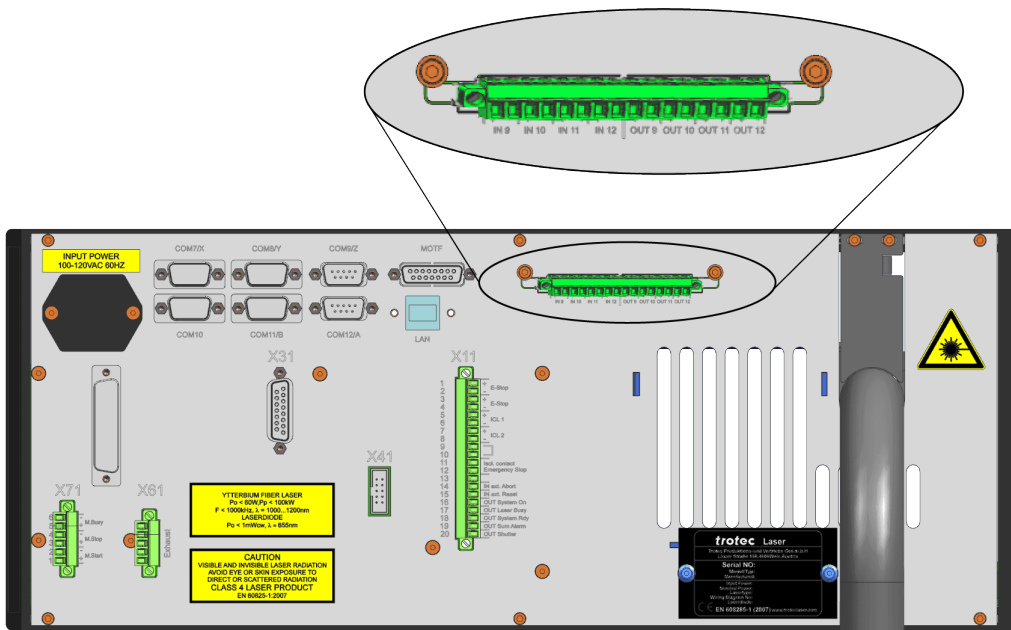

- The inputs have to be provided with a 5V - 24V potential.
- For “ON”, the first PIN (e.g. PIN1) has to be provided with 24V and the second PIN (e.g. PIN2) has to go to ground to ensure the potential.
- The software closes the contact to let the signal from the first PIN (e.g. PIN11) through to the second PIN (e.g. PIN12).
- The outputs sections provide potential free relays contacts.
- The addressing is done by the software. For details please refer to the software manual.

SPECIFICATION:

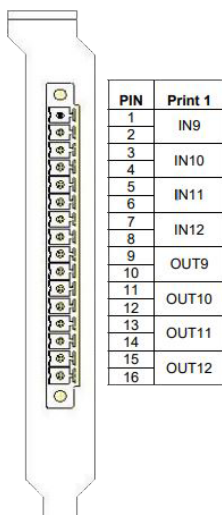

- Maximum number of input signals: 1 per print
- Maximum voltage on output: 24V AC or DC
- Maximum current on each output: 1A

APPLICATION EXAMPLES

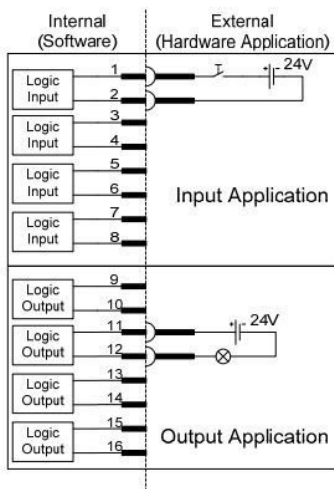

Input with switch and external 24V source at input "IN9".

Supply of a lamp with 24V by activating "OUT10".

8.6.2 Overview PC interface (back side)

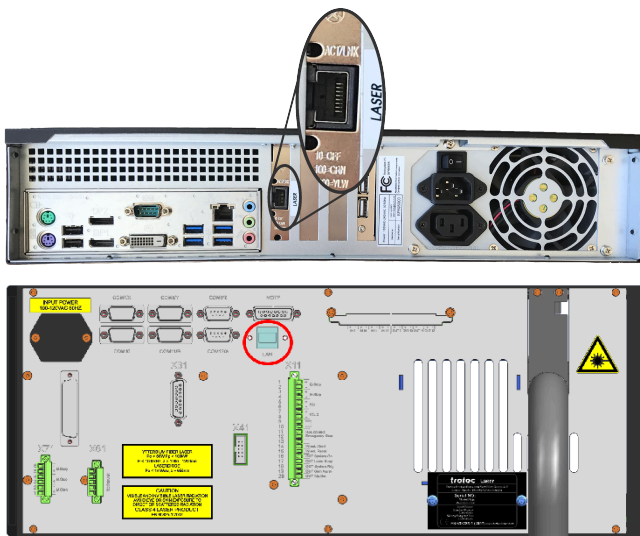

The machine is connected to the Ethernet via a cable connection from the LAN interface on the rear of the PC rack to the LAN interface on the laser rack.

THE FOLLOWING IP ADDRESSES ARE RESERVED:

192.168.0.3	192.168.0.10	192.168.0.13	192.168.0.16	192.168.0.19
192.168.0.5	192.168.0.11	192.168.0.14	192.168.0.17	192.168.0.50
192.168.0.7	192.168.0.12	192.168.0.15	192.168.0.18	

8.6.3 Mains connection

Laser rack and PC have a cold device socket on the rear for the cold device cables supplied.

Setup and installation

Before commissioning, it is essential to check whether the laser rack is configured to the mains voltage and frequency. The configuration of the laser rack is given on the type plate or on the warning label above the IEC connector.



Warning Current

The laser rack is fitted with different main fuses depending on the configured supply voltage:

115V AC	-	1 x 6.3 A "T" speed/time-delay
230V AC	-	2 x 4 A "T" speed/time-delay

The main fuses are located behind the cover, immediately adjacent to the IEC connector.

The same main fuse is used on the PC for all mains voltages.

8.6.4 Interface pin configuration

X11 – Safety circuit (Emergency stop button / interlock safety switch / external messages)

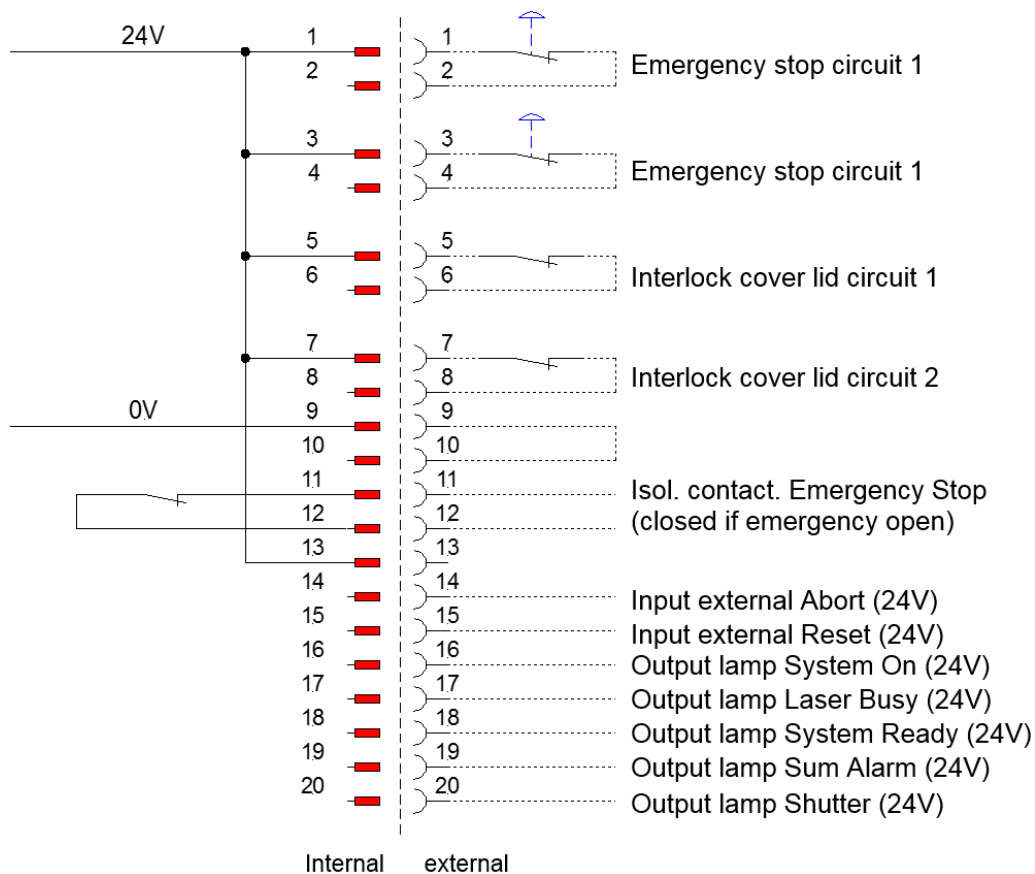

X31 - External panel

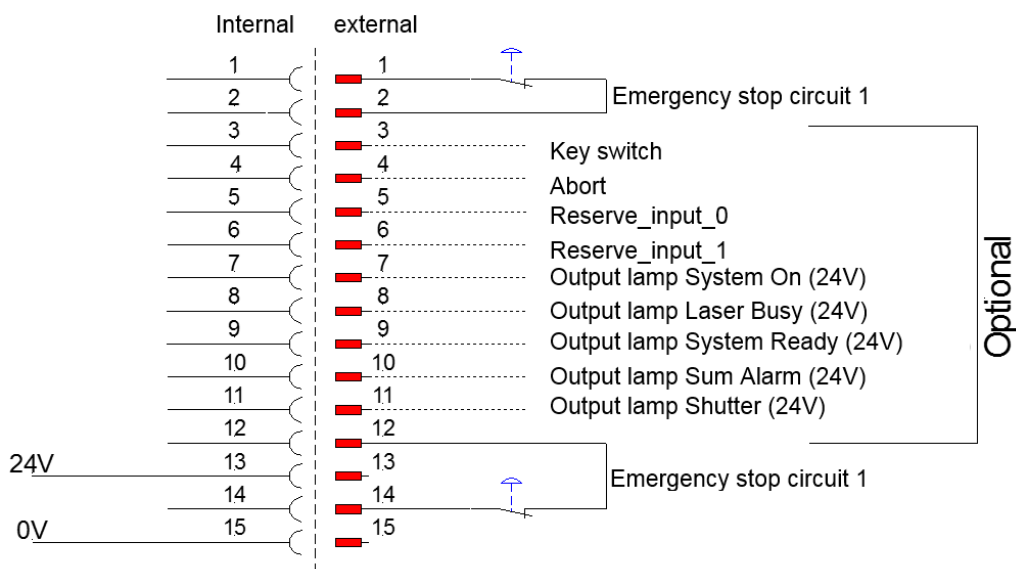

X71 - Start / Stopp



I/O Input/Output

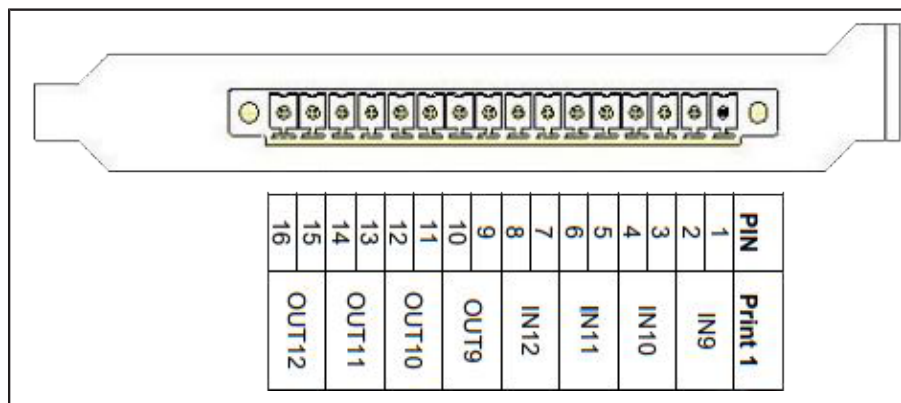

9 Operation

9.1 Installation inspection

The following points must be checked to ensure correct installation:

- Correct power supply connections and fuses.
- Complete and correct mechanical and electrical installation.
- Check that the mechanical and electrical installation is complete and correct Input voltages.
- Checking the purity of the optical components (free of dust and dirt).
- Remove the protective cover from the focusing lens.
- Check the environmental conditions against the technical specification.
- Observe laser safety regulations.
- Check compliance with all laser safety measures. The system may only be switched on if all precautions have been taken to comply with the laser safety have been checked. by an authorized person and found to comply with the standards.

9.2 Marking software

The marking software is included on an accompanying data medium.

For information on using the software, please read the accompanying software manual.

9.3 Control elements

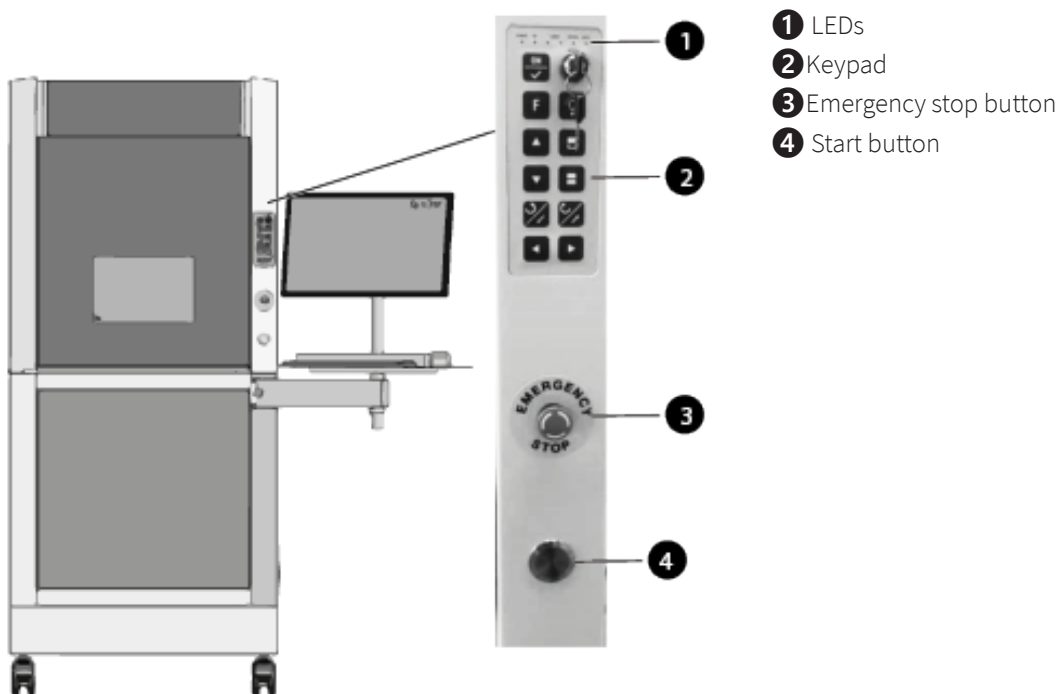

- 1 LEDs
- 2 Keypad
- 3 Emergency stop button
- 4 Start button

LED



LED	Status	Description
POWER	green	Power supply is switched on
ON	green	Laser control is switched on
LASER	green	Laser is active
ERROR	red	Interference, not yet acknowledged
AUTO	green	Automatic mode is active

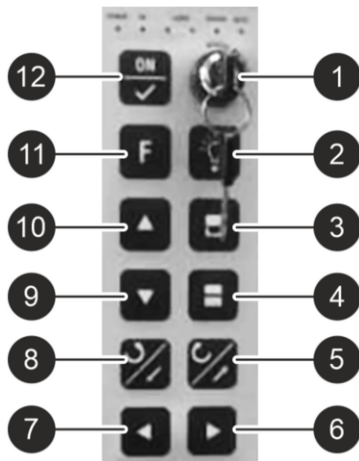

- | | | |
|----|----------------------|--|
| 1 | Key switch | Selection of manual or automatic operation |
| 2 | Button | Lighting in the machining area |
| 3 | Safety door open | Move safety door upwards |
| 4 | Safety door closed | Move safety door down |
| 5 | Button backward (Y) | Move laser to the back |
| 6 | Button right (X) | Move laser to the right |
| 7 | Button left (X) | Move laser to the left |
| 8 | Button forward (Y) | Move laser forward |
| 9 | Button downwards (Z) | Move laser down |
| 10 | Button up (Z) | Move laser upwards |
| 11 | Function key F | Switch between x- and y-axis modes |
| 12 | Button ON | Acknowledge after switching on, emergency stop and fault |



Information

The functions for moving the laser and moving the safety door are only active in the operating mode "Manual".

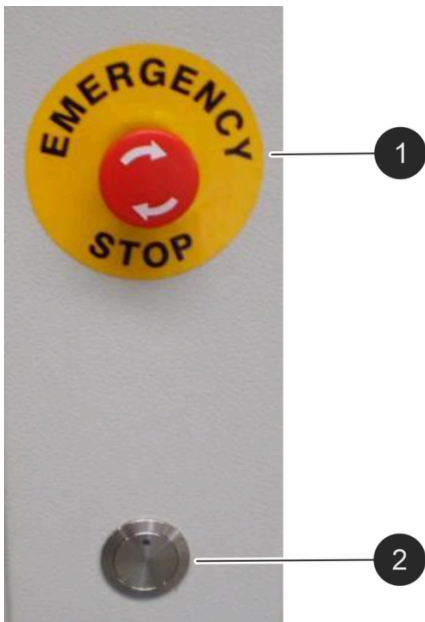

- ① Emergency stop button
 - press in case of danger.
 - Power supply of the PC remains.
- ② Automatic start button
 - Starting processing in automatic mode.

9.3.1 Manual operation

MANUAL CONTROL OF SAFETY DOOR



Button: Safety door open



Button: Safety door closed

SOFTWARE CONTROLLED X- AND Z-AXIS (OPTIONAL: Y-AXIS)

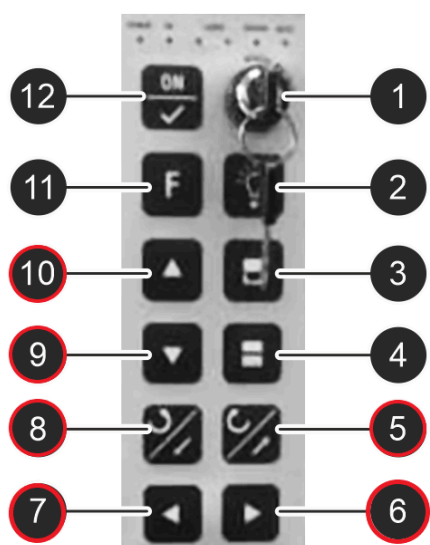

- (5) y-axis back (optional), moving the y-axis backward.
- (6) x-axis right (optional), traverse the x-axis to the right
- (7) x-axis left (optional), move x-axis to the left
- (8) y-axis forward (optional), move y-axis forward
- (9) z stroke down, traverse the z-axis downward
- (10) z stroke up, move the z-axis upwards

- The axes are limited by limit switches.
- When moving, be careful that the lens does not collide with the workpiece.
- After switching on the SpeedMarker or after an emergency stop, a reference run must be carried out. This can either be started manually in the marking software or is automatically queried when the software is started.
- In automatic mode the axes are controlled from the laser PC.



Caution

Risk of crushing when moving the axes.

9.4 Power On/Off

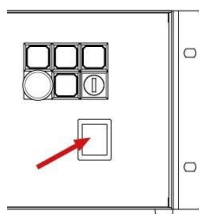

1. Press the main switch (1) on the laser rack.

→ The shutter is closed. The main switch and the two status lamps on the marking head illuminate in yellow.

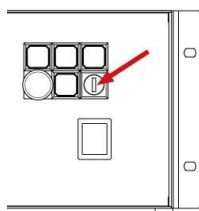

2. Put the key in the key switch (7) (vertically) and turn 90° to the right.

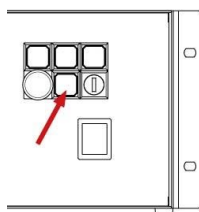

3. Press the Error reset button (6) to reset the system to its normal state.

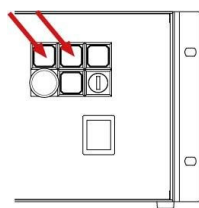

4. The control lamps "System ready" (2) and "Shutter" (3) such as the status lamps on the marking head should now be illuminated. The laser is ready to start marking.



5. Start the PC.

6. Now start the marking software on the PC.

If an error occurs, the control lamp "Error reset" (6) lights up. By pressing this button, the error can be acknowledged and the system is ready to work again.

You can use only the key switch (7) to pause the laser.

The main switch (1) must be set to 0 to switch off the laser completely.

9.5 Automatic mode

In this operating mode, all functions are executed automatically. The operating mode is selected on the control panel with a key switch. The operating mode is intended for an automatic production process. The laser operates only when the safety door is closed.

SEQUENCE OF AUTOMATIC MODE

SpeedMarker 700

1. Open door in manual mode.
2. Start automatic sequence with the "Start" key
3. The safety door closes.
4. The marking process runs automatically.
5. Marking process is completed.
6. The safety door opens.
7. A new marking process can be started with the "Start" key.



SpeedMarker 700RT

1. The automatic sequence is started with the "Start" key.
2. Rotating plate/ bulkhead is rotating.
3. The marking process runs automatically.
4. Marking process is completed.
5. A new marking process can be started with the "Start" key.



Information

The key switch is in the AUTO position and automatic mode has been activated in the control software on the laser PC.

9.6 Emission indicator

The laser system is equipped with an emission indicator.

This is indicated by a separate display on the marking head and/or by a luminous control lamp (shutter) on the laser rack.

MEANING OF THE SIGNAL COLORS

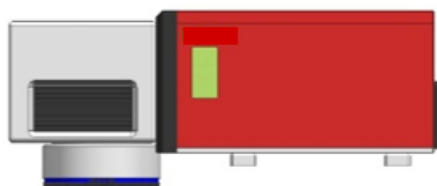

Emission indicator off - Device de-energised.

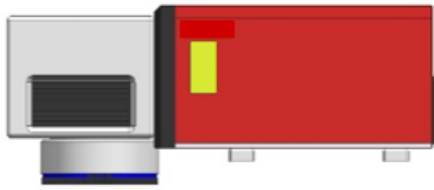

Emission indicator status yellow - shutter is closed, no laser power output.

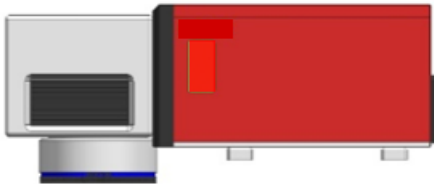

Emission indicator status red - shutter is open, output of laser power possible.



Warning Laser

If the device is switched on or the safety shutter is open there is a danger of laser radiation.

- Pay attention to the emission display.
- Do not open laser marking head.

9.7 Focusing



Notice

It is absolutely essential to maintain the correct focal distance for every laser marking process. Only when in focus will the laser beam achieve the power density necessary for permanent and clearly legible marking.

Prior to any marking it is therefore necessary to set the correct focal distance between the marking head and the workpiece. An incorrect focal distance is the most common cause of poor or even indistinguishable markings.

The focal distance (**A**) is measured between the lower edge of the working galvo head (**B**) and the upper surface of the workpiece (**C**). The correct focal distance depends on the lens used (focal length).

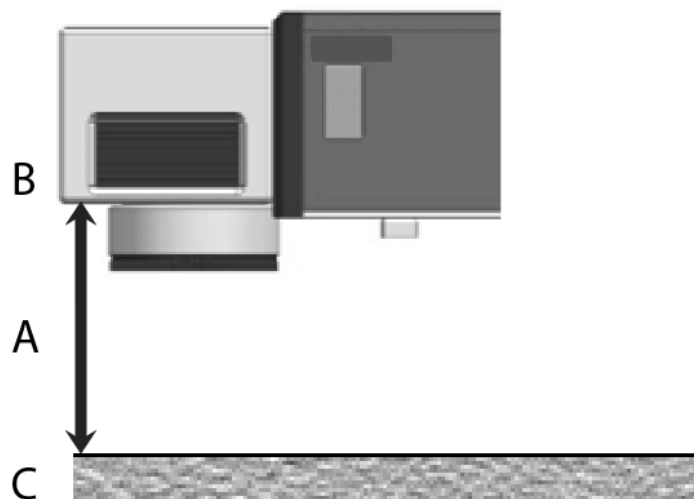

Focal length	Working distance (A)
F=100	134,6 mm
F=160	211,6 mm
F=254	361,6 mm
F=330	456,6 mm
F=420	562,6 mm

9.8 Options

9.8.1 SpeedMarker "DS" Dynamic Shifting

The SpeedMarker DS enables very fast and precise focusing without mechanical movement of the marking head. The optical z-axis built in for this purpose is controlled via the software using the "Focus Shift" function.

The SpeedMarker DS is available in the "D160" and "D254" versions.

The working fields of the SpeedMarker DS result depending on the maximum desired z-stroke.

WORK VOLUME

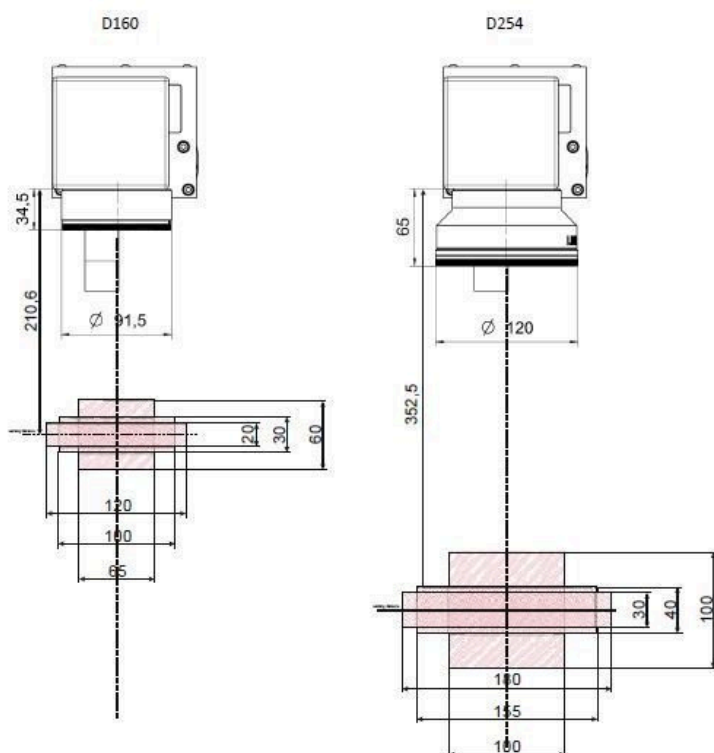



Information

Further and detailed information on the use of the functions can be found in the software manual.

9.8.2 3D-Projection/Virtual Rotary

In addition to the Focus Shift function, it is possible to activate the "3D-Projection" option for xyz-axis systems by means of a license key. This allows various 3D shapes to be labeled flexibly and easily.

9.8.3 SpeedMark Vision - Smart Adjust

The Smart Adjust option is an integrated camera system for user-friendly and highly precise positioning of markings directly on the component by superimposing a camera image on the operator interface.



Information

For further information, please refer to the appendix "Datasheet Smart Adjust" or the manual "SpeedMark Vision Smart Adjust".

10 Ingetration / Connection

10.1 Switching sequences

Switching sequence diagrams are provided for various standard processes which indicate the interplay of the individual signals.

Standard power-up process

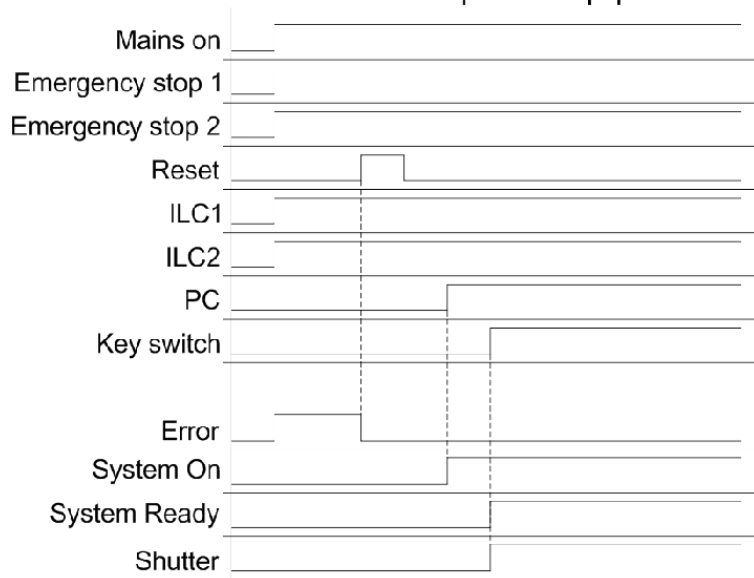

Emergency stop

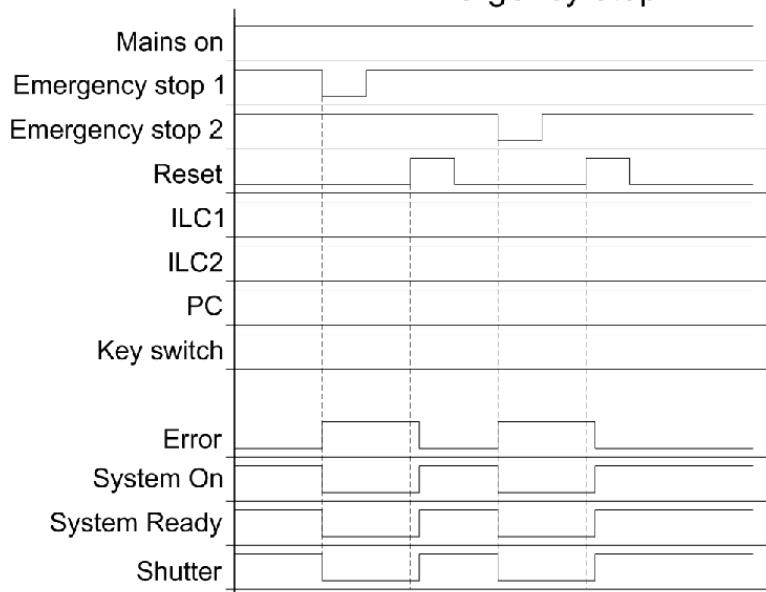

ICL (interlock circuit loop)

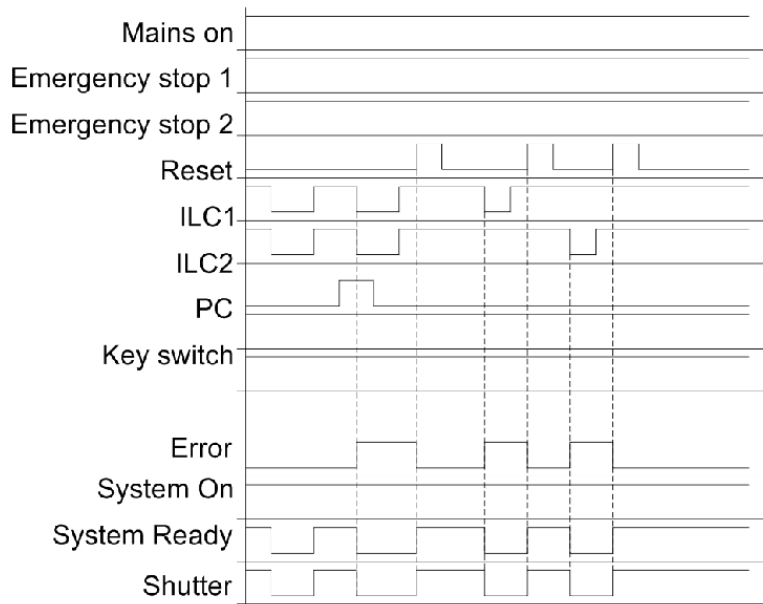

11 Maintenance

11.1 Safety notes



Caution

Before any maintenance work takes place, ensure that the power supply has been switched off and the system is de-energised.



Notice

All maintenance work must be carried out according to the safety regulations.

In order to ensure the maximum availability and lifetime of the system, we recommend you regularly check the filter system and ventilation and keep the surrounding area clean. Before switching on the system, make a visual inspection of the lenses.

11.2 Changing of the laser source filter mat

This laser system is equipped with air cooling. A filter mat is used to protect the electronic components from dust and impurities in the ambient air. This filter mat should be checked and replaced at regular intervals to ensure an optimal cooling situation.

The filter pad is located behind the ventilation slots on the front of the laser rack or on the Pc.

Filter pad on the laser rack:

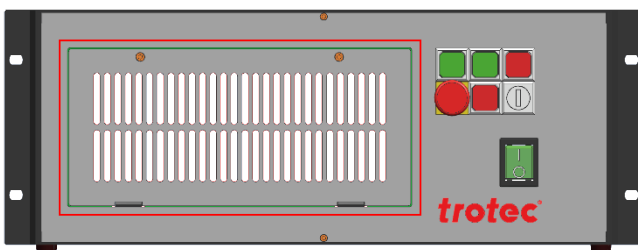

1. Cover of the filter pad.

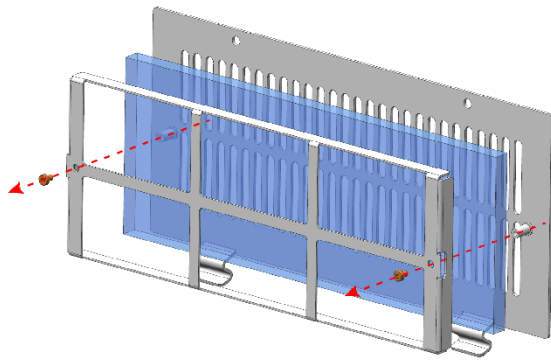

2. Remove both screws and open the cover. Change the filter pad.

11.3 Cleaning the optics

This system is fitted with high quality optical components, which under normal operating conditions are maintenance free for their lifetime. However, it may be necessary to clean output lenses, e.g. the scanner flat field lens (f-theta objective) if it becomes covered in dust or fumes.



Notice

Never touch the optical components with your fingers! Oily or dirty hands may damage the lens surfaces.

Do not use any tools or hard objects to clean the surfaces. Scratches cannot be repaired.

Laser optics are highly sensitive and their surfaces are not as hard as traditional glass. They can also be easily damaged by cleaning. It is therefore necessary to ensure that any dirt is removed using a suitable suction device and that the surrounding area is cleaned regularly.

Small bellows should be used to remove dust.



Notice

Do not use compressed air as it contains small quantities of oil and water.

To remove larger pieces of dirt, only use a lens cleaning cloth with high proof (at least 98%) alcohol.



Notice

Do not dip the cleaning cloth in the cleaning solution. This contaminates the solution and makes it unusable. Place drops of the solution on the cloth!

Apply the cleaning solution carefully in order to avoid scratching the surface of the lens.

Do not wipe the lens with a dry cloth. Do not touch the reverse side of the cloth. Dirt and sebum on the fingers can be transferred to the lens by the cloth and cause damage.

Distribute the cleaning fluid carefully using small circular motions. Start at the center of the lens and move outwards to the edge. Keep moving the cloth until the entire surface is clean.

Do not exert any pressure on the lens.

12 Troubleshooting

This chapter should assist maintenance personnel with the identification and resolution of operational faults based on error messages and symptoms.



Danger

Maintenance and repair work should only be carried out by Trotec Laser GmbH or one of its authorized personnel under observation of the safety regulations.

12.1 Error, cause and remedy

Problem	Possible cause	Remedy
Error message on loading the program.	Plug or cable installed incorrectly.	Check the plug and cable are installed correctly.
	Laser power supply switched off.	Turn on main switch.
	Software not installed correctly.	Re-install software.
	Software terminated irregularly.	Restart computer.
Laser will not switch on.	Plug or cable installed incorrectly.	Check the plug and cable are installed correctly.
	Laser power supply switched off.	Turn on main switch.
	Faulty fuse in laser power supply.	Replace fuse.
Status lamps on marking head remain green.	safety circuit not closed.	Check safety circuit If no safety circuit is connected, use bridging connector X11.
No laser beam.	Laser not in focus.	Check working distance.
	Shutter closed.	Open shutter - if not possible check safety circuit.
	Incorrect laser parameters.	Check the parameters in the program. Use suitable parameters for the material and application.
Insufficient laser output.	Laser not in focus.	Check working distance.
	Incorrect laser parameters.	Check the parameters in the program. Use suitable parameters for the material and application.
Missing symbols.	Focusing lens dirty.	Clean focusing lens.
	Surface of the material dirty.	Clean material surface.
Other faults.		Contact Technical Support.

12.2 Possible error messages

Below is a list of possible errors which may be detected by the system. These will appear in the software as messages on the display.

The Reset signal (X11) or the reset button on the laser rack are used to acknowledge an error. In order for the system to be reset, the error or the corresponding input signal must be acknowledged.



Warning

System errors which cannot be reset or which indicate a hardware error should only be resolved by Trotec Laser GmbH trained service personnel.

Error message	Cause
Card off line.	Software has lost connection to the TLC2 controller
Scanner not connected.	No connection to the galvanometer scanner.
Scanner X error.	The X-axis of the galvanometer scanner has identified an error.
Scanner Y error.	The Y-axis of the galvanometer scanner has identified an error.
Signal cable not connected.	No connection to the marking head.
External abort.	External abort signal identified on X11.
External stop.	External stop signal identified on X11.
Voltage error (15V).	+/- 15V power supply not functioning correctly.
Voltage error (24V).	24V power supply not functioning correctly.
Laser power supply error.	Faulty laser source power supply.
Shutter error.	Shutter has not reached intended position.
Cover connector opened during marking.	ICL1 and ICL2 were opened during the marking process .
External sum alarm.	External error signal identified on X11.
System locked by key switch.	Key switch on laser rack locked.
Laser temperature.	Laser source overheated.
Laser power.	24 V power supply outside the permissible tolerance zone.
Laser not ready for emission.	e.g. key switch not activated.
Laser back reflection.	Back reflection of the laser beam.
Laser system error.	Laser power supply voltage is too high or too low.
Emergency stop button.	Emergency stop button activated.
Error.	+/-15V monitoring.
	24V laser monitoring.
	24V monitoring.
	Shutter temperature.

Error message	Cause
	Required shutter position.

13 Contact details

TECHNICAL SUPPORT

In case of questions, contact our experienced Technical Support in your local area.

For global service contact numbers and further information please see our website, section "Support":

www.troteclaser.com

When calling, please make sure that the machine is in your immediate vicinity, and that you have the following information ready (see response form):

- At which working process did the problem occur?
- What you have done so far to correct the problem.
- Serial no (see type plate).
- Error code.

LOCAL OFFICES / SALES

Our store locator and detailed information on our offices in your area can be found on our website in section "Contact", "Local Office": **www.troteclaser.com**

TECHNICAL DOCUMENTATION

For feedback or to suggest changes to this manual, contact:

Technical documentation: +43 (0) 7242 239 - 7000

E-Mail: **technical.documentation@troteclaser.com**

14 Disassembly



Warning

Danger of injury when disassembling the machine.

There is danger of injury when disassembling the machine.

Always wear suitable protective clothing (e.g. safety goggles, safety shoes, safety gloves).



Warning Current

Electric current.

The machine must be disconnected from the main power supply.



Notice

- Always use suitable tools to disassemble the machine.
- Mind the springs.
- Follow chapter "Disposal".

PROCESS:

1. Remove all workpieces from the system.
2. Turn the key switch to switch off the machine.
3. Switch off the main switch at the back of the machine.
4. Remove the exhaust system.
5. Disconnect all cables at the back of the machine.

15 Disposal



Disposal

Do not dispose of the machine with domestic waste!

Electronic devices have to be disposed of according to the regional directives on electronic and electric waste disposal.

In case of further questions, please ask your supplier.

In case of disassembly, use suitable tools to dismantle the unit into individual parts. Sort the individual parts and have them disposed of professionally. Legal regulations must be adhered to.

16 Appendix

EC–Declaration of Conformity

(Machine directive 2006/42/EG, appendix II A)

Manufacturer:

TROTEC Laser GmbH
Linzer Straße 156,
A-4600 Wels

Authorized person for the compilation of technical documentation:

Gerhard KREMPL, TROTEC Laser GmbH, Linzer Straße 156, A-4600 Wels

We hereby certify that

SpeedMarker 700
Modell N° SM700

in its conception, construction and form put by us into circulation is in accordance with all the relevant essential health and safety requirements of the EC machinery directive 2006/42/EEC.

Further valid guidelines/regulations for the product:

2014/35/EG Low Voltage Directive
2014/30/EG EMC Guideline

Applied harmonized standards:

- EN ISO12100:2011-03 Machine Safety
- EN ISO11553-1:2016 Safety of machinery – Laser processing machines
- EN 60204-1:2011-01 Machine Safety – electr. Equipment
- EN 60825-1:2015-07, EN 60825-4:2011-12 Safety of Laser Equipment
- EN 61000-6-4:2011-09 Electromagnetic Compatibility

Place, Date:

Wels, 7/15/2016

Personal data of the signer:

Georg ERNST, Head of Research and Development

Signature:





SpeedMarker 700



Fiber Laser

Laser	Gepulster Yb-Faserlaser, wartungsfrei				
Wavelength	1064 nm				
Beam quality	$M^2 < 2$				
Power stability	better $\pm 5\%$				
Cooling	air cooled				
Laser type	FL 20	FL 30	FL 50	FL 20 MOPA	FL 100 MOPA*
Max. average output power	20 W	30 W	50 W	20 W	100 W
Max. pulse energy	1 mJ	1 mJ	1 mJ	1 mJ	1 mJ
Pulse repetition rate [kHz]	2 - 200	2 - 200	2 - 200	1,6 - 1000	10-1000
Adjustable pulse duration	x	x	x	✓	✓
Pulse duration [ns]	100 \pm 20	100 \pm 20	100 \pm 20	1,5;2,5;4;8;16;30; 50;120;200;350	20; 30; 60; 120
Integrated pilot laser	✓	✓	✓	✓	✓

Galvo System

Lens / Focal length	F-100	F-160	F-254	F-330	F-420
Marking area [mm x mm]	70 x 70	120 x 120	190 x 190	240 x 240	310 x 310
Focus diameter	~ 27 μ m	~ 45 μ m	~ 68 μ m	~ 88 μ m	~ 112 μ m
Max. marking speed	800 cps – 1 mm single line mit F = 160 mm				
Max. positioning speed	12.000 mm/s bei F = 160 mm				

*Not available in combination with rotary table

Control

Computer	Integrated industrial PC as 19" rack unit, 2RU high, Windows® 10
Interfaces	USB, Ethernet, RS232,
Interfaces laser	Laser-interlock, marking-start (24 VDC), marking-stop (24 VDC), E-stop, error-reset, laser-busy, optional digital I/O's (24 VDC),
Software	SpeedMark, DirectMark (fiber laser)

Workstation with software-controlled Z-axis

Laser	Fiber laser				
Maximum part height	570 mm <i>F-100</i>	493 mm <i>F-160</i>	343 mm <i>F-254</i>	248 mm <i>F-330</i>	142 mm <i>F-420</i>
Minimum part height	26 mm	--	--	--	--
Laser marking field [W x D in mm]	70 x 70	120 x 120	190 x 190	240 x 240	310 x 310
Maximum working area [W x D in mm]	Corresponding to laser marking field				
Maximum load	50 kg				
Working table	T-slot plate (Isel PT 25): 375 x 400 mm ² Optional: 700 x 375 mm ²				
Axis system	software-controlled Z-axis				
Travel distance Z-axis	500 mm				

Workstation with software-controlled X-, Y- and Z-axis

Laser	Fiber laser r				
Maximum part height	546 mm <i>F-100</i>	469 mm <i>F-160</i>	319 mm <i>F-254</i>	224 mm <i>F-330</i>	118 mm <i>F-420</i>
Minimum part height	16 mm	--	--	--	--
Laser marking field [W x D in mm]	70 x 70	120 x 120	190 x 190	240 x 240	310 x 310
Maximum working area [W x D in mm]	390 x 350	440 x 400	510 x 435	560 x 460	580 x 495
Maximum load	30 kg				
Working table	T-slot plate (Isel PT 25): 375 x 400 mm				
Axis system	Software-controlled X-, Y- und Z-axis				
Travel distance X- / Y- Z-axis	320 / 280 / 500 mm				

Workstation RT with rotary table

Laser	Fiber laser				
Maximum part height (limited due to partition panel)	195 mm <i>F-100</i>	195 mm <i>F-160</i>	195 mm <i>F-254</i>	195 mm <i>F-330</i>	142 mm <i>F-420</i>
Information about minimum part height	140 mm	68 mm	--	--	--
Laser marking field [W x D in mm]	Caution: With <i>F-100</i> and <i>F-160</i> lens it is not possible to focus onto the surface of the rotary table due do collision with the partition panel. This needs to be considered for flat parts (carrier might be needed).				
Maximum load	70 x 70	120 x 120	190 x 190	240 x 240	310 x 310
Working table	20 kg with symmetric loading				
Axis system	Plate with mounting and centering holes Diameter 550 mm Height of partition panel: 200 mm				
Travel distance Z-axis	Software-controlled Z-axis <i>X-axis upon request</i>				
Travel distance Z-axis	450 mm				

Optionen / Zubehör

Optional lenses and galvo Scanners	<u>Fiber laser:</u> F-100, F-160, F-254, F-330, F-420
SpeedMark Vision – Smart Adjust	Integrated camera system for positioning support. Different camera lenses with different image sizes and resolutions are available --> please refer to the datasheet "SpeedMark Vision – Smart Adjust".
Extended I/O interface	Additional in- and outputs, 24 VDC
Rotary indexing table	Only in combination with fiber laser
Additional optional accessories	<ul style="list-style-type: none"> • Rotary units with different chucks for fiber laser • Foot switch for efficient and user friendly control of the system • Exhaust systems
Industrial PC – high performance	Optional and more performant version of industrial PC (CPU, HDD, RAM, graphics card) for graphical applications.
Modified door with lower opening	Door with lower opening

Dimensions / Installation / Laser Safety

	Workstation with Fiber laser	Workstation RT With rotary table	
Dimensions [W x H x D in mm]	780 x 1802 x 981	780 x 1804 x 1144	
Interior dimensions [W x D in mm]	737 x 894	737 x 794	
Height of base plate [H in mm]	971	956	
Door opening [W x H in mm] (on base plate)	580 x 365	210 x 200 <i>Partition panel</i>	
Loadable height of part (with base plate / with Y-axis)	345 / 318	---	
Option seated work position: Overall height [H in mm]	1662	1664	
Option seated work position: Height of base plate [H in mm]	831	816	
Optional door with higher opening: Door opening [W x H in mm] (on base plate)	580 x 504	---	
Optional door with higher opening: Loadable height of part (with base plate / with Y-axis)	484 / 457	---	
Door	Manual and/or automatic; Optional: rotary table		
Weight	ca. 260 kg	ca. 300 kg	
Ambient conditions	Operating temperature range +5 to +35°C Relative humidity max. 90 %; non-condensing		
Electrical requirements	230 VAC, 16 A, 50/60 Hz, 1/N/PE		
Power consumption	< 1400 W		
System protection	Marking head: sealed against spray water (IP 54) Laser rack unit: dust protected (IP20)		
Laser class	CDRH laser safety Laser class 2 CE tested		
Color	RAL 3002, RAL 7016, RAL 7035		

Interior (optional software-controlled Z- and X-axis – ZX0)

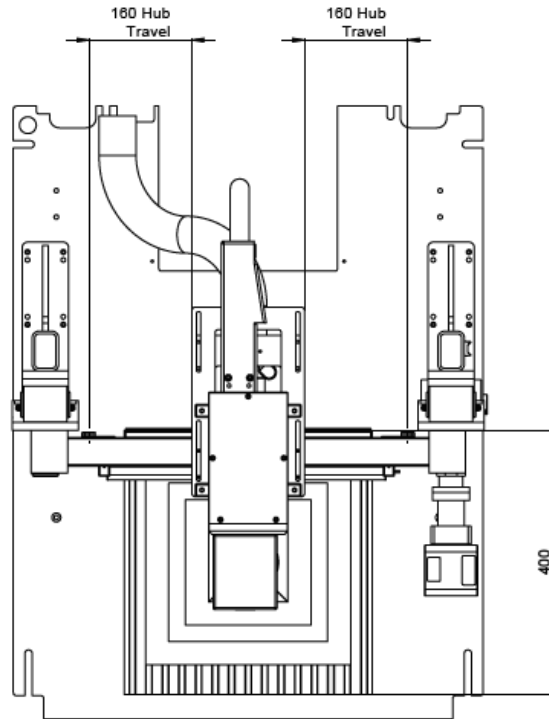

Top view with software-controlled Z- and X-axis

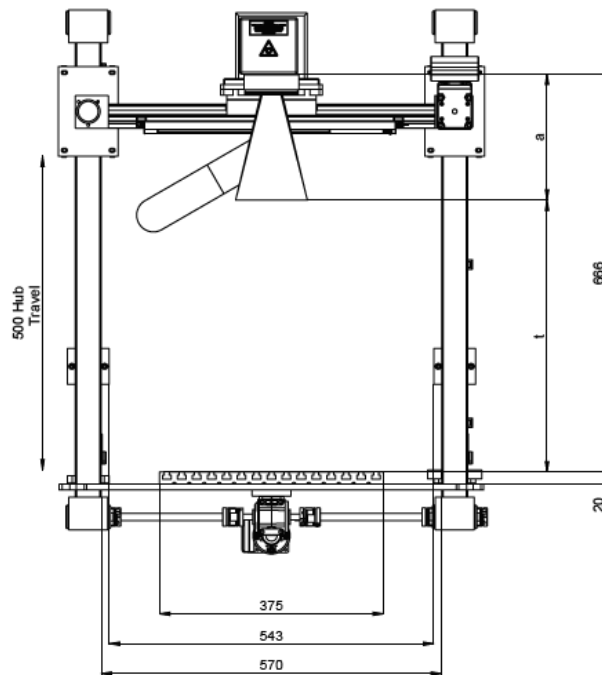

Top view with software-controlled Z- and X-axis

Interior (optional software-controlled Z-, X- and Y-axis – ZXY)

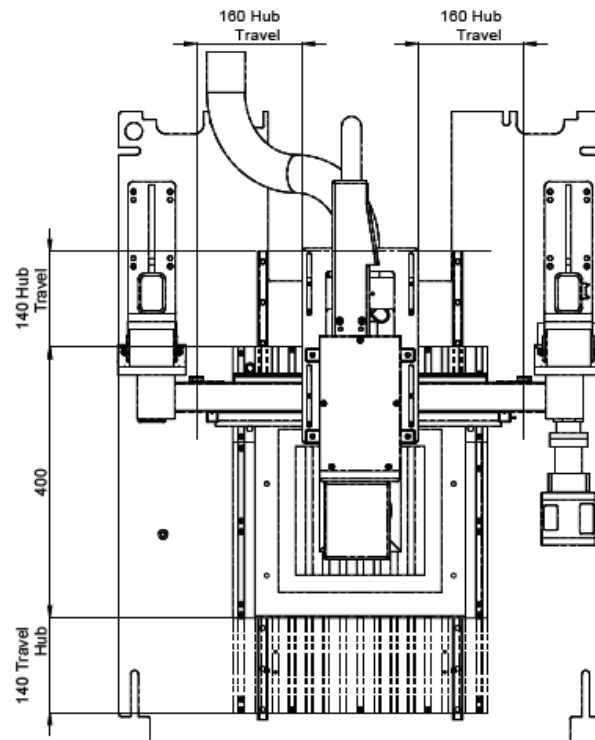

Top view with software-controlled Z-, X- and Y-axis

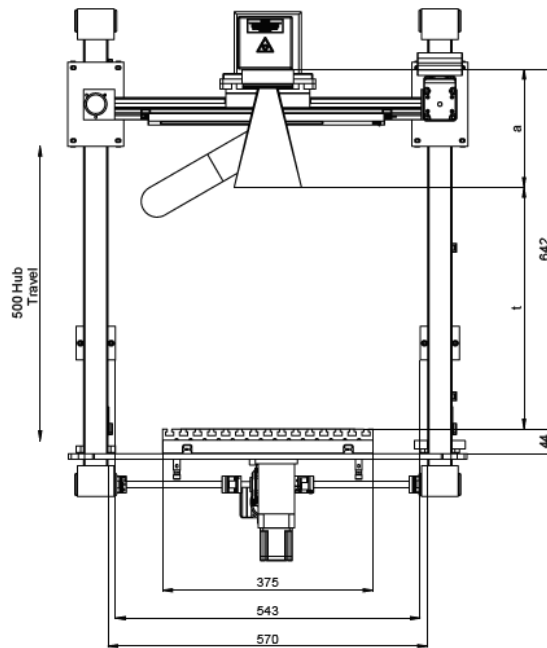

Top view with software-controlled Z-, X and Y-axis

Interior (version with rotary table)

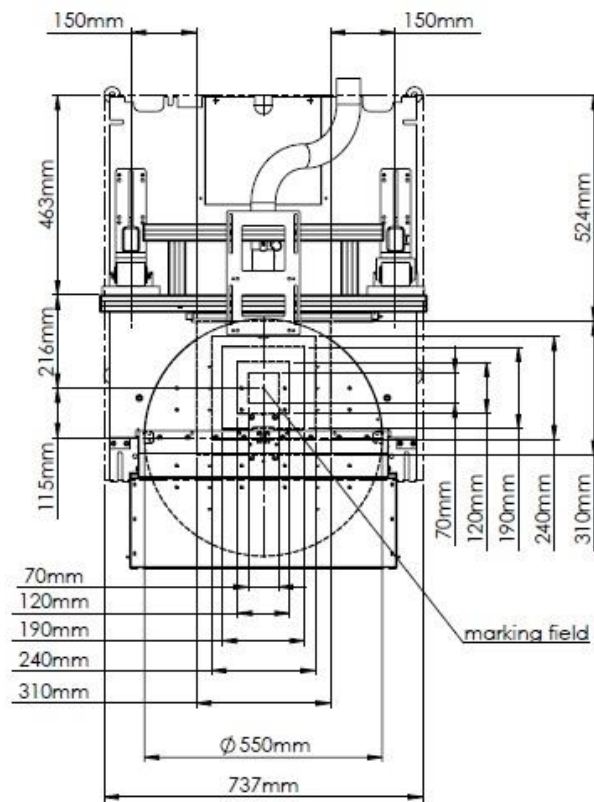

Top view with rotary table

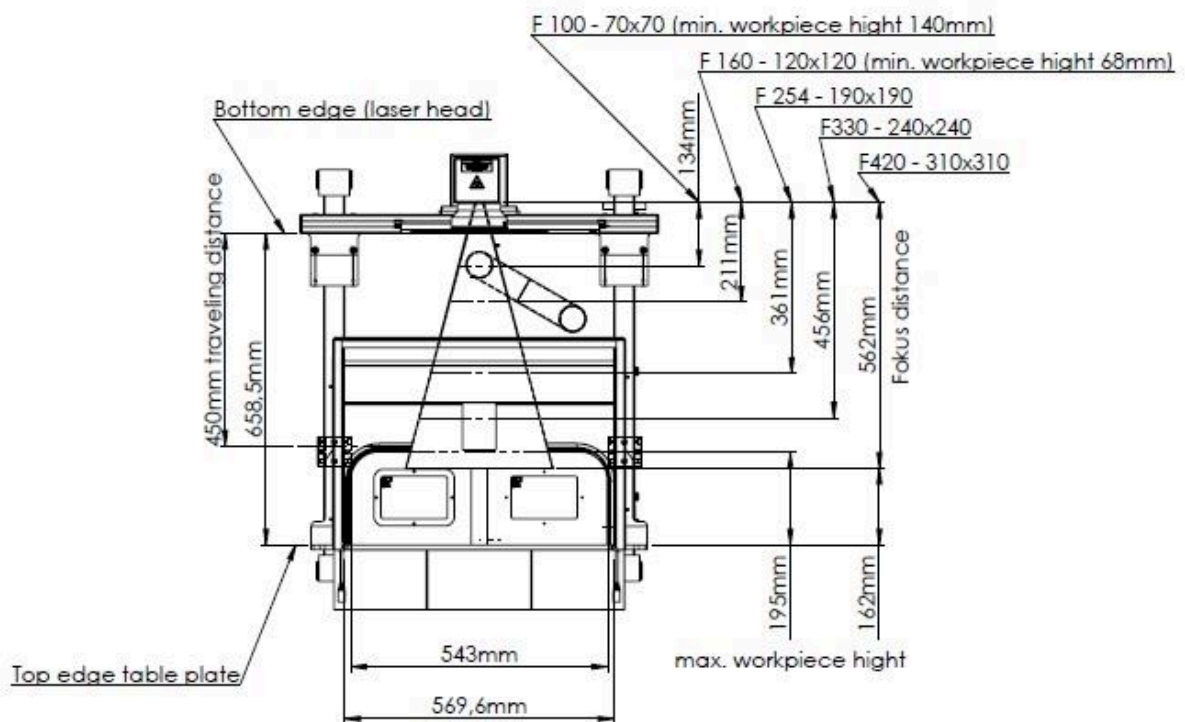

Top view with rotary table

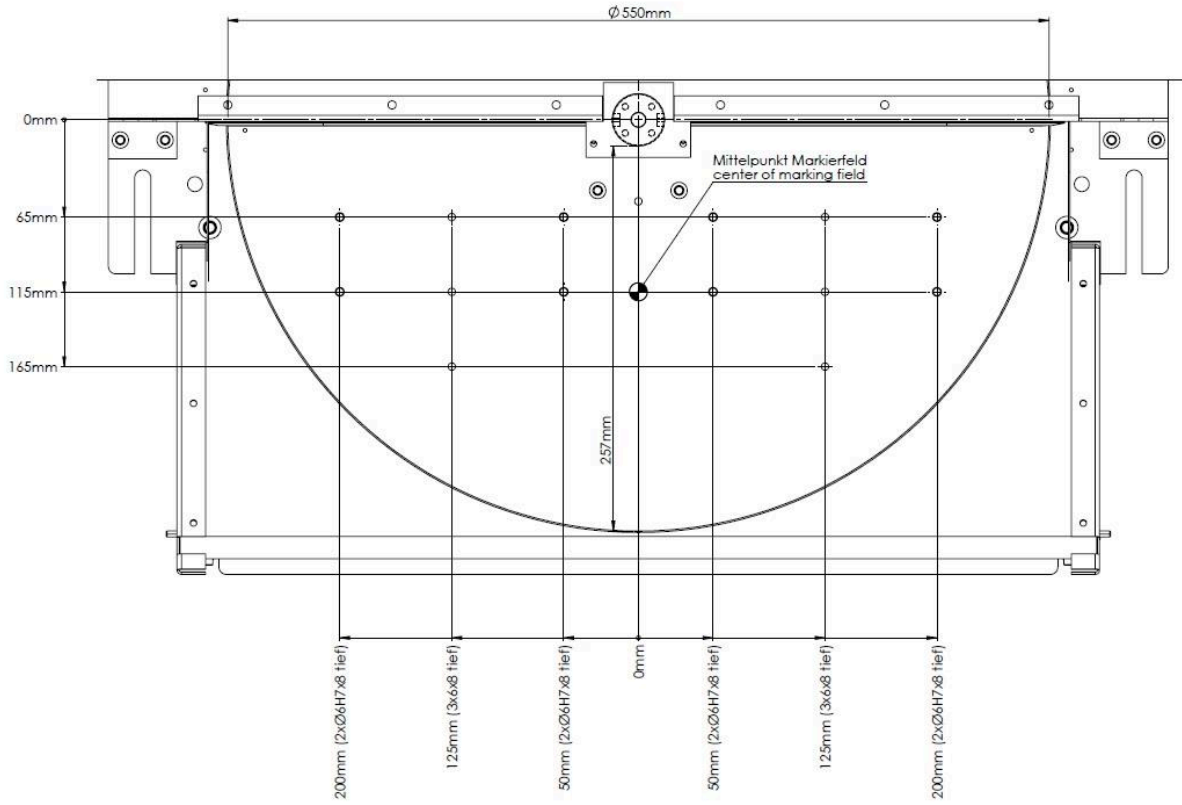

Rotary table

Exterior dimensions

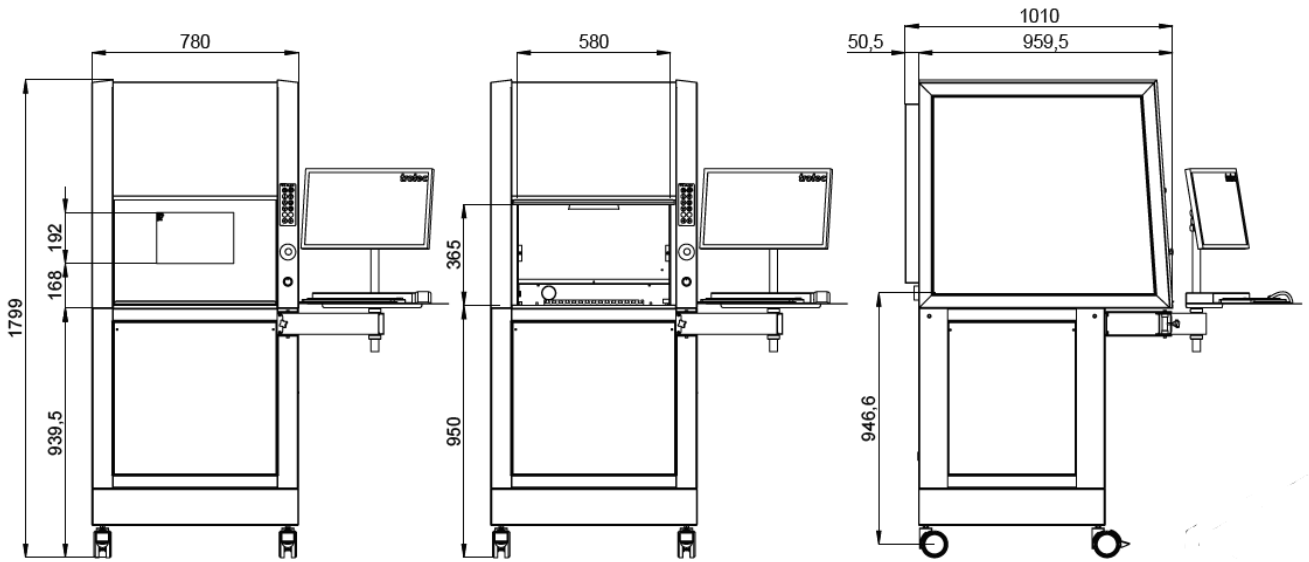

Exterior dimensions

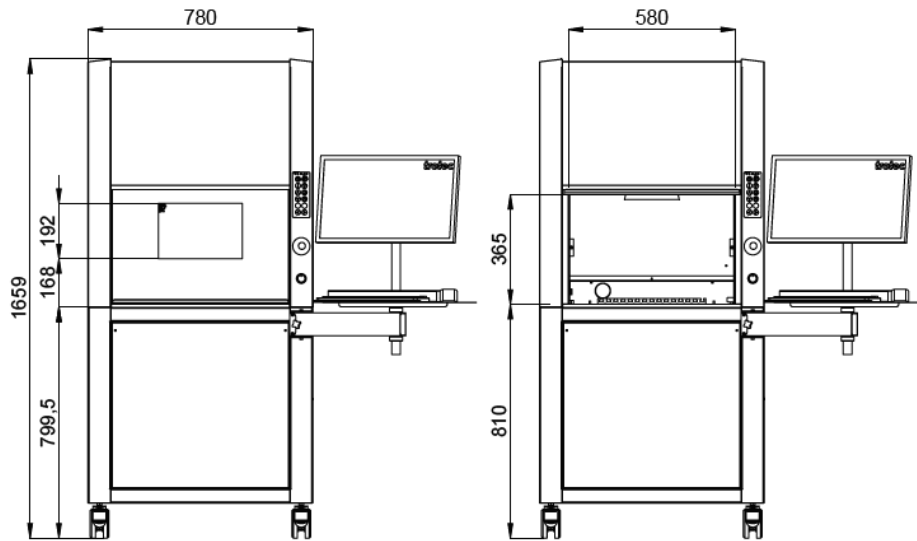

Exterior dimensions sedentary workstation – option low door

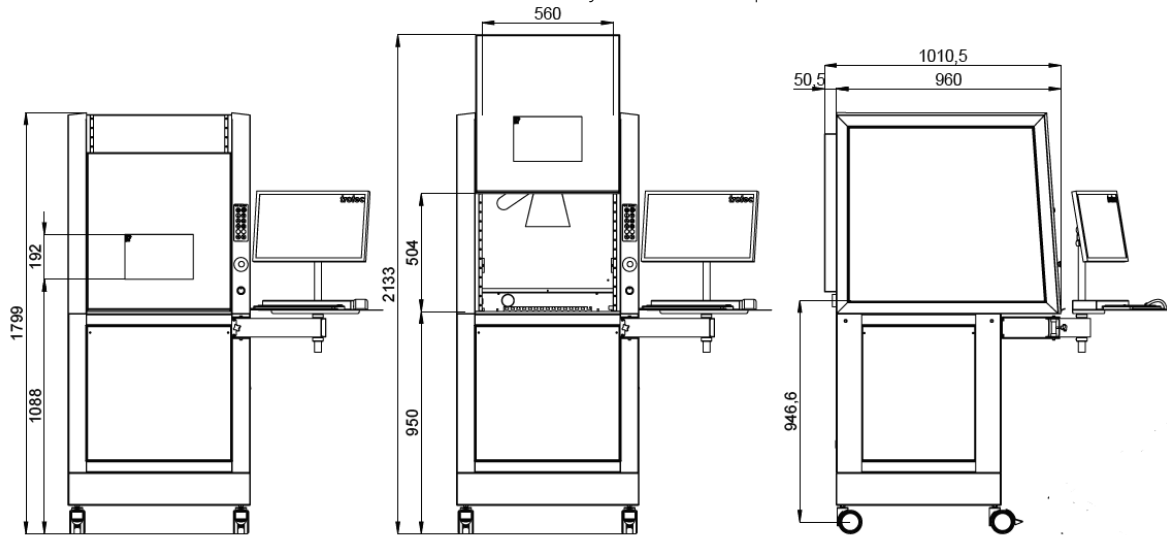

High door

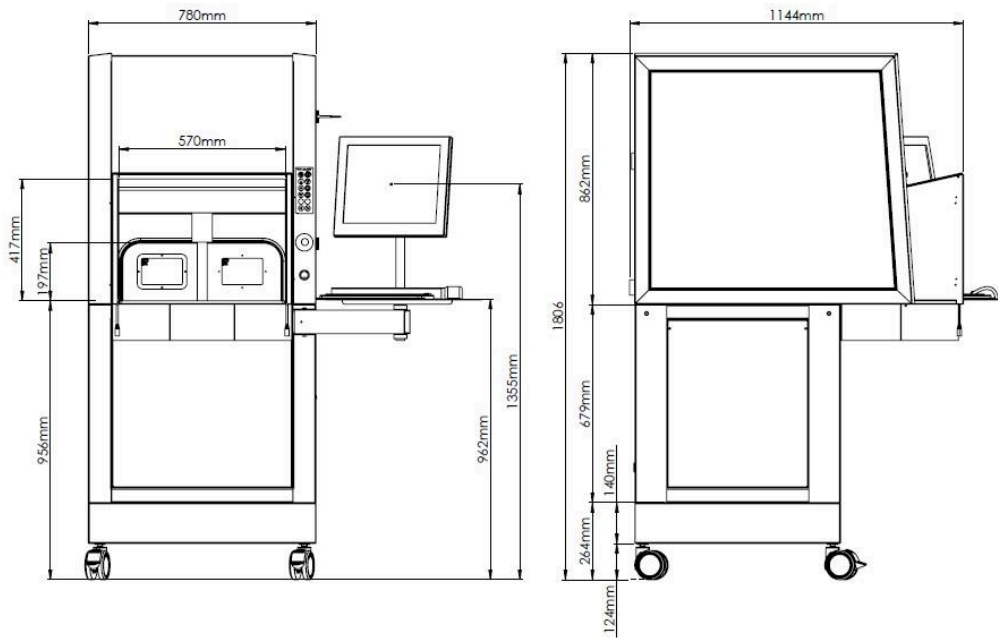

Exterior dimensions with rotary table

Setup

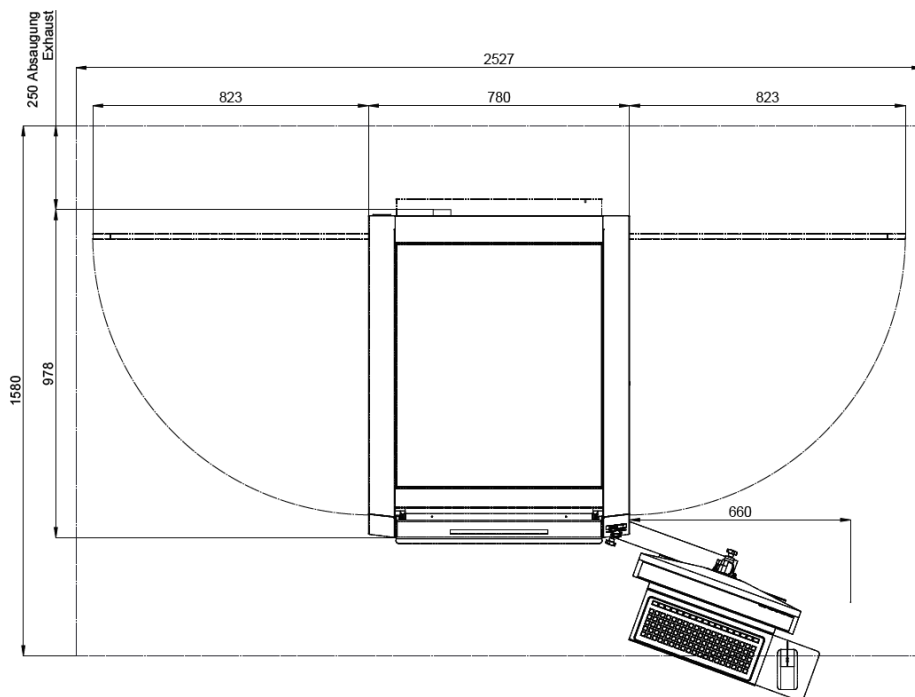

Setup

Tolerances on Dimensions: 1%
 Content subject to change without prior notice.
 Updated: December 2019

- **SpeedMark Vision – Smart Adjust**
Integrated camera system for user friendly and precise positioning of markings directly on the product. Camera image is shown directly in the GUI of the laser software

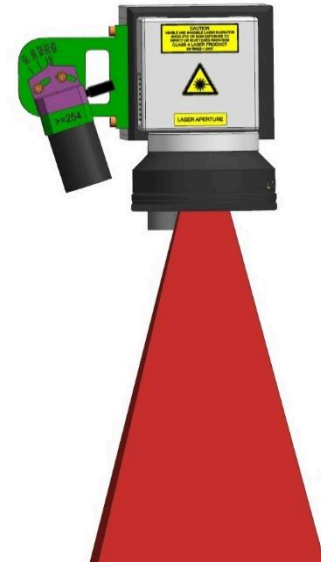

Camera und Lens

Sensor type	CMOS
Interface	USB 2.0
Optical class	1/2 "
Resolution class	10,55 MPixel
Camera resolution	3840 x 2748 Pixel
Pixel size	1.67 µm
Lens type	C-Mount
Focal length of camera lens	f = 8,5 mm; 12 mm; 25 mm

Compatibility / Accessories

Available for following products	SpeedMarker 300, 700, 1300, FL (OEM)
Software	SpeedMark 3.6
Camera package without lens	Material number: 98778 (Retrofit kit: 98781)
Lenses	<ul style="list-style-type: none"> • f = 8,5 mm: Material number: 98777 • f = 12 mm: Material number: 92385 (default) • f = 25 mm: Material number: 92386 (precision)



Size of camera image (depending on lens)

F-Theta lens laser	F-100	F-160	F-254	F-330	F-420
Marking field laser [mm]	70 x 70	120 x 120	190 x 190	240 x 240	310 x 310
8,5 mm lens [mm]	~ 140 x 100	~ 188 x 135	~ 290 x 208	~ 317 x 247	~ 432 x 309
12 mm lens [mm] (default)	~ 87 x 62	~ 116 x 73	~ 187 x 134	~ 218 x 160	~ 257 x 195
25 mm lens [mm] (precision)	~ 34 x 24	~ 50 x 37	~ 90 x 65	~ 113 x 80	~ 138 x 100

Resolution depending on camera lens

F-Theta lens laser	F-100	F-160	F-254	F-330	F-420
8,5 mm lens	27 Pixel/mm	20 Pixel/mm	13 Pixel/mm	11 Pixel/mm	9 Pixel/mm
12 mm lens (default)	43 Pixel/mm	33 Pixel/mm	20 Pixel/mm	17 Pixel/mm	14 Pixel/mm
25 mm lens (precision)	112 Pixel/mm	75 Pixel/mm	41 Pixel/mm	33 Pixel/mm	27 Pixel/mm

