

**trotec**

# SpeedMarker 1600

Operating manual



**8059**

OM 8059\_1.10\_EN (01/2024)  
ENGLISH (Translation)

/ SETTING NEW STANDARDS

(AT)

**Trotec Laser GmbH**

☎ +43 7242 239-7070  
service-at@troteclaser.com

(CA)

**Trotec Laser Canada**

☎ +1 800 663 1149-902  
techsupport@troteclaser.ca

(DE)

**Trotec Laser Deutschland GmbH**

☎ +49 89 322 99 65-13  
service-de@troteclaser.com

(GB)

**Trotec Laser UK**

☎ +44 0191 4188 110  
service-uk@troteclaser.com

(MX)

**High Speed Laser Systems S. de R.L. de C.V.**

☎ +52 55 5351-7252  
mexico@troteclaser.com

(US)

**Trotec Laser Inc.**

☎ +1 866 226 8505, Option 2  
support@troteclaser.com

(AU)

**Trotec Laser Pty Ltd**

☎ +61 26413-5904  
service@troteclaser.com.au

(CH)

**Trotec Laser AG**

☎ +41 32387-1611  
service-ch@troteclaser.com  
suisse@troteclaser.com

(ES)

**Trotec Laser España**

☎ +34 93 102 50 50  
soporte@troteclaser.com

(IT)

**Trotec Laser Srl**

☎ +39 02 9475 5447  
supporto.tecnico@troteclaser.com

(NL)

**Trotec Laser B.V.**

☎ +31 850 70 51 55  
support@troteclaser.nl

(ZA)

**Rubber Stamp & Engraving**

☎ +27 875 509-335  
support@trodat.co.za

(BE)

**Trotec Laser België  
Trotec Laser Belgique**

☎ +31 850 70 51 55  
support@troteclaser.nl

(CN)

**Trotec Laser GmbH**

☎ +86 189 500 735 62  
china@troteclaser.com

(FR)

**Trotec Laser France SAS**

☎ +33 1 72 62 20 94  
techsupport.fr@troteclaser.com

(JA)

**Trotec Laser Japan Corporation**

☎ Tokyo: +81 42 313 0740  
☎ Osaka: +81 6 6180 2200  
service-jp@troteclaser.com

(PL)

**Trodat Polska Sp. z o.o.**

☎ +48 22 339 35 39  
serwis\_pl@trodat.net

**Trotec Laser (XIAMEN) CO., LTD.**

#5 GuAn Road South, MaXiang  
Town  
XiangAn District, XiaMen, China

---

**Trotec Laser GmbH**

Freilingenstraße 99  
4614 Marchtrenk, Austria

**General contact to Technical Support:**

Tel.: +43 7242 239-7000

E-mail: [techsupport@troteclaser.com](mailto:techsupport@troteclaser.com)

**[WWW.TROTECLASER.COM](http://WWW.TROTECLASER.COM)**

- 
- Technical Changes      Technical specifications are subject to change without notice.  
Trotec Laser GmbH reserves the right to improve or modify any of the products without prior notice.
- © Copyright              This documentation with all illustrations is intellectual property of Trotec Laser GmbH. The entire documentation is given to the user for personal use only. Reproduction, translation or any distribution to third parties is not permitted without the prior consent of Trotec Laser GmbH. Any breach of law will be prosecuted.

## Content

<b>1</b>	<b>Introduction.....</b>	<b>8</b>
<b>2</b>	<b>General Information.....</b>	<b>9</b>
2.1	<b>Information about this manual.....</b>	<b>9</b>
2.1.1	Information about this manual.....	9
2.1.2	Storage of the manual.....	9
2.1.3	General instructions for using the manual.....	9
2.2	<b>Explanation of symbols.....</b>	<b>10</b>
2.3	<b>Liability and warranty.....</b>	<b>10</b>
2.4	<b>Scope of delivery (standard configuration).....</b>	<b>11</b>
2.5	<b>Type plate.....</b>	<b>11</b>
<b>3</b>	<b>Safety.....</b>	<b>13</b>
3.1	<b>General safety notes.....</b>	<b>13</b>
3.1.1	Intended use.....	14
3.1.2	Improper use.....	14
3.1.3	Residual risk.....	14
3.1.4	Machine modification.....	14
3.1.5	Operating modes.....	15
3.1.6	Applicable safety regulations.....	15
3.2	<b>Laser safety.....</b>	<b>16</b>
3.2.1	Laser classification.....	16
3.3	<b>Areas of responsibility.....</b>	<b>17</b>
3.3.1	Responsibilities of the operator.....	17
3.3.2	Responsibilities of the operating personnel.....	18
3.4	<b>Requirements for operating an service personnel.....</b>	<b>18</b>
3.5	<b>Machine identification (warning and safety stickers).....</b>	<b>18</b>
3.6	<b>Secondary (indirect) hazards.....</b>	<b>21</b>
3.6.1	Fire hazard.....	21
3.6.2	Gases, fumes and dust.....	21
3.7	<b>In case of emergency.....</b>	<b>22</b>
<b>4</b>	<b>Technical Data.....</b>	<b>23</b>
4.1	<b>Electrical requirements of the machine.....</b>	<b>23</b>
4.2	<b>Exhaust system requirements.....</b>	<b>23</b>
4.3	<b>Connecting a cooling unit.....</b>	<b>25</b>
<b>5</b>	<b>Machine overview.....</b>	<b>26</b>
5.1	<b>General overview.....</b>	<b>26</b>
5.2	<b>Machining area.....</b>	<b>27</b>

<b>5.3</b>	<b>Control elements.....</b>	<b>29</b>
5.3.1	System control.....	29
5.3.2	Laser rack.....	30
5.3.3	Industrial PC.....	31
<b>5.4</b>	<b>Safety devices.....</b>	<b>31</b>
<b>6</b>	<b>Before commissioning.....</b>	<b>34</b>
6.1	Unloading, inspection and reporting faults.....	34
<b>7</b>	<b>Transport and Storage.....</b>	<b>35</b>
7.1	Transport conditions.....	35
7.2	Storage conditions.....	36
7.3	Place of storage.....	36
7.4	Transport inspection and reporting of defects.....	36
<b>8</b>	<b>Setup and installation.....</b>	<b>37</b>
8.1	For your safety.....	37
8.2	Temperature and humidity.....	37
8.3	Installation location.....	37
8.4	Electrical installation.....	38
8.4.1	Overview laser rack interface (back side).....	38
8.4.2	Overview PC interface (back side).....	42
8.4.3	Mains connection.....	43
<b>9</b>	<b>Operation.....</b>	<b>44</b>
9.1	Installation inspection.....	44
9.2	Marking software.....	44
9.3	Control elements.....	45
9.4	Manual operation.....	47
9.5	Emission indicator.....	47
9.6	Focusing.....	48
9.7	Options.....	49
9.7.1	SpeedMarker “DS” Dynamic Shifting.....	49
9.7.2	3D-Projection/Virtual Rotary.....	50
9.7.3	SpeedMark Vision - Smart Adjust.....	50
<b>10</b>	<b>Maintenance.....</b>	<b>51</b>
10.1	Safety notes.....	51
10.2	Changing of the laser source filter mat.....	51
10.3	Cleaning the optics.....	52
<b>11</b>	<b>Troubleshooting.....</b>	<b>53</b>
11.1	Error, cause and remedy.....	53
11.2	Possible error messages.....	54

12	Contact details.....	56
13	Disassembly.....	57
14	Disposal.....	58
15	Appendix.....	59
15.1	CE_8059_SpeedMarker_1600_D.....	60
15.2	Datasheet 8059 SpeedMarker 1600.....	61
15.3	Datasheet Smart Adjust.....	63

### 1 Introduction

The SpeedMarker 1600 fiber is a second generation of a high quality marking laser. The Yb fiber laser source means the system has an extremely long life cycle and minimal maintenance costs. This system is maintenance free apart from the filter pad and processing lens.

The combination of a high quality galvanometer scanner and a fiber laser produce highly precise marking results in short marking times.

This, together with the marking software and the available interfaces, provides a flexible and productive marking solution of the highest quality standards.

The operator of the laser marking system is obliged to observe the “Applicable safety regulations” as described in the chapter “Safety”.



## 2 General Information

### 2.1 Information about this manual

#### 2.1.1 Information about this manual

**Before beginning any work on the machine, read this manual completely and carefully.  
Keep the manual for further consultation close to the machine.**

This manual describes how to operate the machine properly and safely. Be sure to follow the safety instructions given here, as well as any local accident prevention regulations and general safety regulations applicable to the field of usage. Before beginning any work on the machine, ensure that the manual, in particular the chapter entitled “Safety Information” and the respective safety guidelines, has been read in its entirety and fully understood.



#### **Information**

Supplementary documentation can be found on the supplied storage medium. You can also request this from the manufacturer.

#### 2.1.2 Storage of the manual

This manual is an integral part of the machine and must therefore be kept in its immediate vicinity and be accessible at all times.

#### 2.1.3 General instructions for using the manual

The operating manual describes how to handle the device correctly and safely and guides you through the necessary steps for initial use. The operating manual also contains important information regarding system maintenance.



#### **Warning**

This operating manual must be read and followed carefully before commissioning and operating the device. Failing to observe individual points listed in this operating manual may result in personal injury and/or material damage to property!

This system may only be operated using devices and spare parts included in the scope of supply or the replacement or list of spare parts.

Ancillary devices must be calibrated to meet the safety and operational requirements of the base machine (please contact your dealer or the manufacturer with any queries).

### 2.2 Explanation of symbols

Important technical safety notes and instructions in this manual are indicated by symbols. It is important to observe and follow these notes and instructions on workplace safety. Avoid accidents, personal injury and material damage to property by acting with extreme caution.



#### **Danger**

This symbol indicates an imminently hazardous situation which, if not avoided, will result in death or serious injury.



#### **Warning**

This symbol indicates a potentially hazardous situation which, if not avoided, could result in death or serious injury.



#### **Warning Dangerous electrical voltage**

This symbol warns of potentially dangerous situations related to the electric voltage. Failure to observe the safety instructions leads to risk of serious injury or death. Particular care should be taken during maintenance and repair work.



#### **Warning Laser**

This symbol warns of potentially dangerous situations related to the laser beam. Failure to observe the safety instructions leads to risk of serious injury.



#### **Caution**

This symbol indicates a potentially hazardous situation which, if not avoided, could result in minor or moderate injury.



#### **Notice**

This symbol indicates potential risks of damage to the supported product (or to property).

In addition, non-observance may result in damage, malfunction or failure of the machine.



#### **Information**

This symbol indicates tips and information which must be observed for efficient and trouble-free handling of the product.



#### **Disposal**

This symbol indicates notes regarding the professional disposal of the product or accessories.

### 2.3 Liability and warranty

Warranty periods specified in the manufacturers “warranty terms and conditions” shall be binding for the buyer. If no warranty periods are specified, the general terms and conditions of sale, delivery and payment apply.

All information, illustrations, tables, specifications and diagrams contained in this operating manual have been carefully compiled according to the current state of technology. No liability is accepted with regard to errors, missing information and any resulting damage or consequential loss.

Strict compliance with the safety procedures described in this operating manual and extreme caution when using the equipment are essential for avoiding and reducing the possibility of personal injury or damage to the equipment. The manufacturer shall not be liable for any damage and or faults resulting from nonobservance of instructions in this manual.

Nonobservance of the operation, maintenance and service instructions described within this manual absolves Trotec Laser GmbH from any liability in case of a defect.

Furthermore, Trotec Laser GmbH shall accept no liability whatsoever for damage caused by the use of non-original parts and accessories.

Additionally, Trotec Laser GmbH shall not be held responsible for any personal injury or property damage, of an indirect or specific nature, consequential loss, loss of commercial profits, interruption to business, or loss of commercial information resulting from use of the equipment described in this manual.

It is strictly prohibited to make any alterations, to prepare translations, decompile, disassemble, reverse engineer or copy the software.

Trotec Laser GmbH reserves the right to update any of the information, illustrations, tables, specifications and diagrams contained in this operating manual with regard to technical developments at any time without notice.

### 2.4 Scope of delivery (standard configuration)

- SpeedMarker 1600
- Software and manuals on storage medium
- Lens cleaning tissues
- Allen key set
- Key for Rack
- Key for Workstation
- Exhaust connection cable (optional)
- Accessories SpeedMark Vision (optional)
- Power Cord
- Monitor, keyboard, mouse



#### **Notice**

The system should be returned and transported in the original packaging.

### 2.5 Type plate

The type plate contains information regarding the serial number, manufacturer, date of manufacture, connection values and consumption data.

## General Information

---

The type plate is located on the reverse side of the laser machine.

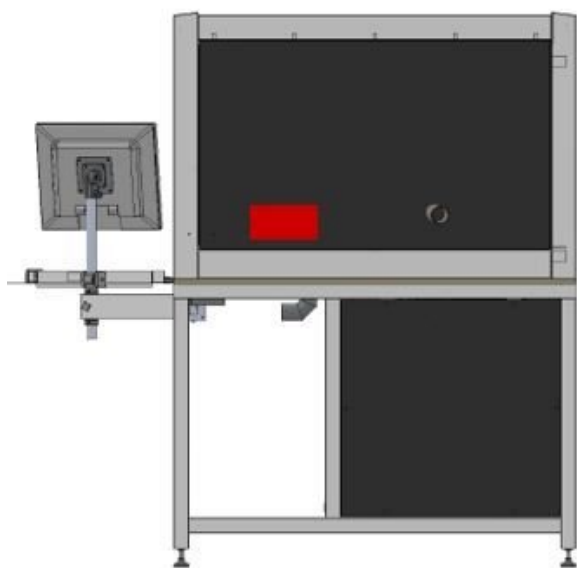

**Enter the serial number, model and year of construction of the machine here.**

This data is important should the unit experience a fault and for ordering replacement parts.

Serial number:	
Model:	
Year of manufacture:	

## 3 Safety

### **TO AVOID POSSIBLE HARM READ AND FOLLOW THESE INSTRUCTIONS.**

The machine is built at the time of its development and production according to applicable, established technical rules and is considered to be safe to operate.

Dangers can be caused by the machine if the machine:

- is operated by unqualified personnel,
- the personnel have not been trained,
- the machine is used improperly or not as intended,
- or if the machine is used for other intended purposes.

This chapter provides an overview of all important safety aspects that are necessary for optimum protection of persons and safe and trouble-free operation of the machine. Other chapters of this manual contain specific safety notes for the avoidance and prevention of hazards.

### 3.1 General safety notes

#### **GENERAL SAFETY NOTES:**

- Only trained persons may perform activities on the machine.
- Safety devices, protective devices and machine parts must be present and must not be bridged. Faultless and intended function must be ensured.
- Work and control of the machine only by persons with sufficient knowledge of the function of the machine (applies especially to service operation).
- Never leave the machine unattended during operation. When the machine is not in use, turn off the main switch.
- Replace detached or damaged machine signage immediately.
- In the event of an unmanageable malfunction, switch off the machine and contact technical support in order not to damage the machine.
- The use of inferior spare parts or third-party components impairs the safety of the machine and renders the declaration of conformity (CE) supplied invalid.
- Protective equipment:  
Wear suitable work clothing and protective goggles matched to the laser (laser class 4).
- Exhaust system:  
Use suitable extraction equipment, as gases, fumes and other partially toxic by-products may be generated.
- Materials:  
Select suitable parameters for the corresponding material. Safely extract dusts so that no detectable residues or residues can collect in the work area.

### 3.1.1 Intended use

The SpeedMarker 1600 is a Class 2 laser marker as per DIN EN 60825-1 "Safety of laser products". It is intended for integration in systems and lines.

The product is intended exclusively for laser marking using the supplied marking software.

The following points should also be observed as part of the intended use:



#### Notice

- Only mark approved materials using suitable parameters.
- Perform maintenance and service according to the specifications in this operating manual.
- Use a suitable extraction system to remove fumes, dust or other reaction products.
- The machine may only be operated by suitably trained individuals.
- Observe effective safety regulations and the procedures described in this operating manual.

If the intention is to use the system for other applications, Trotec Laser GmbH should be informed in advance.

### 3.1.2 Improper use

Use of the machine for any purposes other than those intended or described in the present manual is regarded as improper and therefore prohibited. Trotec Laser GmbH will not accept any liability for damage caused by improper use. The operator is solely liable for all damages caused by improper use.

Non-observance of the operation, maintenance and service instructions described within this manual absolves Trotec from any liability in case of a defect.

### 3.1.3 Residual risk

Even if all safety regulations are observed, a residual risk remains when operating the machine.

The measures required to reduce all residual risks can be found in the following paragraphs of the chapter "[Safety](#)".

### 3.1.4 Machine modification

It is strictly prohibited to alter, refit or modify the machine in any way without the express consent of the manufacturer.

Likewise, it is strictly prohibited to remove, bridge or bypass any safety devices. Operating conditions and connection and setup values stated in the data sheet must be complied with at all times.

Operation of the system is permitted only with original parts and accessories by the manufacturer. Use of third-party parts affects machine safety.

### 3.1.5 Operating modes

#### NORMAL OPERATION

**For normal operation the following conditions must be met:**

- Intended use of the machine (see chapter “Intended use”).
- Operation of the machine only by trained personnel.
- Full functional and mounted safety devices.
- Machine must be in technically flawless condition.
- Processing of permissible materials according to the material list.
- Maintenance and service are not included.



#### Notice

During normal operation it is not necessary to wear safety glasses.

#### SERVICE OPERATION

Service activities may be carried out only by authorized, trained service technicians. If side panels as well as covers get removed and safety devices get bypassed, it can lead to direct and indirect scattered radiation. The service operation is therefore declared as laser class 4 (US: class IV) and proper precautions need to be taken (see “Laser classification”).

### 3.1.6 Applicable safety regulations

The following directives and guidelines must be observed to avoid hazards when operating Trotec laser systems:

#### GUIDELINES/REGULATIONS

2006/42/EC	EC Machinery Directive
2014/30/EU	EMC Guideline

#### APPLIED HARMONIZED STANDARDS

EN ISO 12100:2011-03	Safety of machinery - General principles for design - Risk assessment and risk reduction.
IEC 60825-1:2014, EN 60825-4:2011	Safety of laser products - Part 1: Equipment classification and requirements.
IEC 60204-1:2005	Safety of machinery - Electrical equipment of machines - Part 1: General requirements.
ISO/DIS 11553-1:2009-03	Safety of machinery - Laser processing machines - Part 1: General safety requirements.
IEC 61000-6-4:2007-02	Electromagnetic compatibility (EMC) - Part 6-4: Generic standards - Emission standard for industrial environments.
ISO 13857:2008	Safety of machinery - Safety distances to prevent hazard zones being reached by upper and lower limbs.



### Notice

#### Safety norms and regulations.

The general guidelines and directives listed within this manual may differ according to locality, region or country.

Therefore, always observe the directives as well as the regulations of the institutions for statutory accident insurance association applicable to you. The operator is responsible for fulfilling all safety requirements, as Trotec Laser GmbH has no influence on the proper use of the machine.

Observe the official regulations for your business location in accordance with the applicable local legal regulations (on accident prevention regulations or employee protection), e.g. DGUV regulation 11 for Germany.

## 3.2 Laser safety

### 3.2.1 Laser classification

The laser safety class indicates the risk potential from accessible laser radiation.

The laser system is a Class 2 (US: Class II) laser marking system as per IEC 60825-1 "Safety of Laser Product".

The integrated laser source is a Class 4 (US: Class IV) laser marking system according to IEC 60825-1 and identified as such.

#### Class 2 (US: class II)

The accessible laser radiation of Class 2 (US: Class II) laser systems does not pose any hazard for the skin. Diffuse reflections as well as any short-term irradiation of the eyes (exposure time max. 0.25 seconds) also pose no risk due to the low output power. However, it is possible to suppress the natural eyelid closure reflex and stare into the class-2 laser beam for a time long enough for the eyes to get injured.



### Warning Laser

#### Laser radiation of Class 2 (US: class II)

For Class 2 (US: class II) laser is short term exposure (up to 0.25 seconds) harmless to the eyes and can therefore be operated without additional protective measures. However it can cause irritation of the eyes if the natural avoidance reaction (staring into the laser beam deliberately) or eyelid closure reflex is suppressed.

- Do not suppress the eyelid closure reflex.
- Do not stare directly into the laser beam.
- Close eyes, turn away.
- Never look at the laser beam directly with an optical instrument, e.g. a lens.



**Notice**

It is the responsibility of the operator to comply with the national official and statutory regulations for the operation of a laser system with a build in laser source of class 4 (US: class IV).

### 3.3 Areas of responsibility

#### 3.3.1 Responsibilities of the operator

**The operator has the following responsibilities:**

- It is the responsibility of the operator to comply with the national official and statutory regulations for the operation of a class 4 (US: class IV) laser system or laser system with a build in laser source of class 4 (US: class IV).
- In addition to the safety notes and instructions stated in this manual, consider and observe the local accident prevention regulations and general safety regulations that apply at the operation site of the machine.
- A CO<sub>2</sub> fire extinguisher must always be at hand, as the laser beam can ignite flammable materials.
- If the machine is used industrially, the operator is subject to the legal obligations concerning industrial safety.
- All personnel involved in installation, set-up, operation, maintenance and repair of the machine must have read and understood this manual and in particular the “Safety” section. The personnel must be trained and informed about all the functions, potential dangers and safety issues of the machine on a yearly basis.
- The user is recommended to prepare company internal instructions considering the occupational qualifications of the personnel employed in each case, and the receipt of the instruction/this manual or the participation in the introduction/training should in each case be acknowledged in writing.
- Keep the manual in the immediate vicinity of the machine so that it is accessible at all times to all persons working on or with the machine.
- Authority for the individual activities relating to the application of the machine (e.g. installation, operation, maintenance and cleaning) must be clearly defined and observed, so that no unclear competencies result under the aspect of safety. This applies in particular to work to be performed on the electrical equipment that may only be performed by qualified specialists.
- Maintenance and repair work as specified in the manual must be carried out regularly.
- For all activities concerning installation, set-up, start-up, operation, modifications of conditions and methods of operation, maintenance, inspection and repair, the switch-off procedures that may be provided in the manual must be observed.
- Provide appropriate personal protection equipment (e.g. protective goggles according to wavelength and laser power).
- The operator is responsible for the safety-related state of the machine.
- Do not store any flammable materials in the working area or in the immediate vicinity of the device. Particularly, residues of processed materials have to be removed to prevent any fire hazard.
- The operator must ensure cleanliness and accessibility at and around the machine by corresponding instructions and controls.

## 3.3.2 Responsibilities of the operating personnel

### The operating personnel has the following responsibilities:

- Always wear personal protective equipment.
- It is the duty of the operating personnel to check the machine before start of work for externally visible damage and defects, and to immediately report any changes that appear (including behavior during operation) that may affect the safety of the machine. It must be made sure that the machine is operated only in perfect condition.
- The machine must not be left unattended while it is operating (supervised operation).
- Switch off the machine described herein at the main switch for periods of non-use.
- Operate the machine described here only with a lens in place. A missing lens may cause the unfocused laser beam to be reflected out of the housing.
- Stop this machine immediately in case of failure.
- No working methods are permitted that affect the safety of persons or of the machine.
- The machine and its components, such as the lens and mirrors, are to be kept clean at all times.



### Caution

The adjustment of the beam path may only be carried out by service personnel of Trotec Laser GmbH.

## 3.4 Requirements for operating an service personnel

### The requirements for the operating and service personnel are:

- The personnel must have read and understood this manual and in particular the “Safety” section.
- The personnel must not be under the influence of drugs, alcohol or reactivity affecting medication when working on or with the machine.
- The personnel must be familiar with using the CO<sub>2</sub> fire extinguisher.
- The personnel must be trained in order to be qualified to operate the machine. If the personnel lack the necessary knowledge for working on or with the machine, they must first be trained and note down the training in the training verification form.

Activity	Intended user group	Definition
Control/operation/other activities (e.g. troubleshooting, maintenance)	Qualified personnel or Trotec service technicians	Qualified personnel are those who can judge the work entrusted to them and detect potential risks based on their occupational training, knowledge and experience as well as their understanding of the relevant regulations.

## 3.5 Machine identification (warning and safety stickers)

The warning and information signs are attached to the device at those points which could represent a source of danger before commissioning or during operation. Therefore, pay special attention to the information on the signs.



**Caution**

**Lost or damaged warning and safety stickers.**

If any warning and safety stickers are lost or damaged, the user is not able identify risks anymore, and there is danger of injury.

- Replace lost or damaged labels immediately.
- Contact your Trotec Laser GmbH dealer for details.

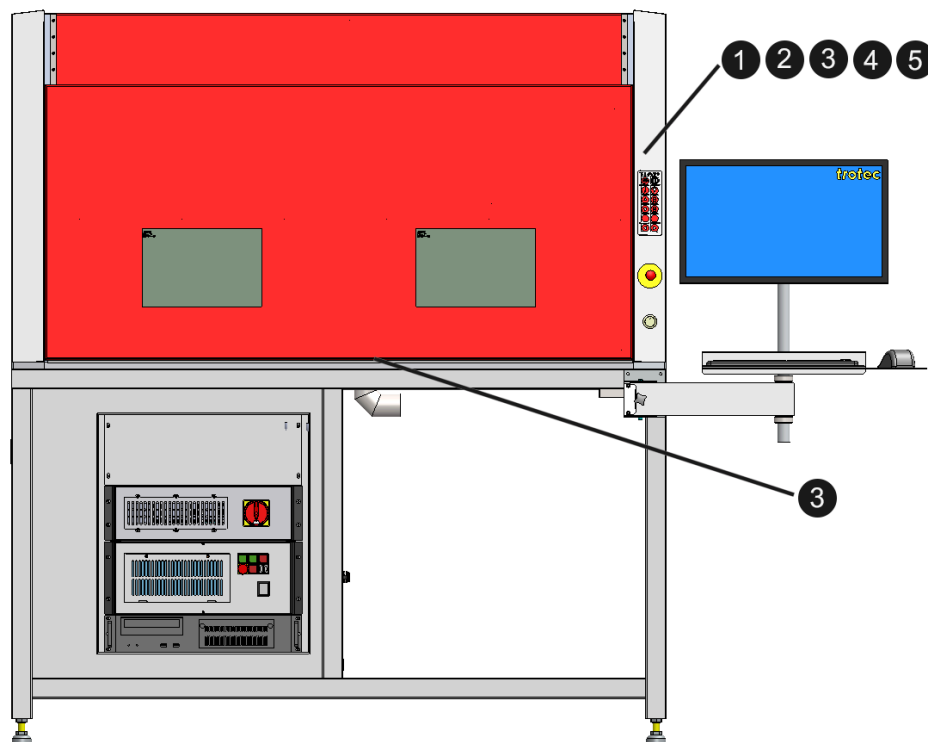

2

YTTERBIUM FIBER LASER  
 $P_0 < 60 \text{ W}$ ,  $P_p < 30 \text{ kW}$ ,  $E_p < 2 \text{ mJ}$   
 $\lambda = 1050 \dots 1200 \text{ nm}$   
 LASERPOINTER  
 $P_{\text{max}} < 0,99 \text{ mW cw}$ ,  $\lambda = 655 \text{ nm}$

4

**CAUTION**  
 VISIBLE LASER RADIATION **CLASS 2**  
 WHEN OPENED  
 DO NOT STARE INTO BEAM  
 per IEC 60825 - 1:2015-07

3

**CAUTION**  
 INVISIBLE LASER RADIATION **CLASS 4**  
 WHEN OPENED AND  
 SAFETY INTERLOCKS DEFEATED  
 AVOID EYE OR SKIN EXPOSURE TO  
 DIRECT OR SCATTERED RADIATION  
 per IEC 60825 - 1:2015-07

5

**ATTENTION !**  
 NEVER OPERATE THE LASER SYSTEM  
 WITHOUT CONSTANT SUPERVISION!  
 EXPOSURE TO THE LASER BEAM MAY  
 CAUSE IGNITION OF COMBUSTIBLE  
 MATERIALS WHICH CAN CAUSE SEVERE  
 DAMAGE TO THE EQUIPMENT!

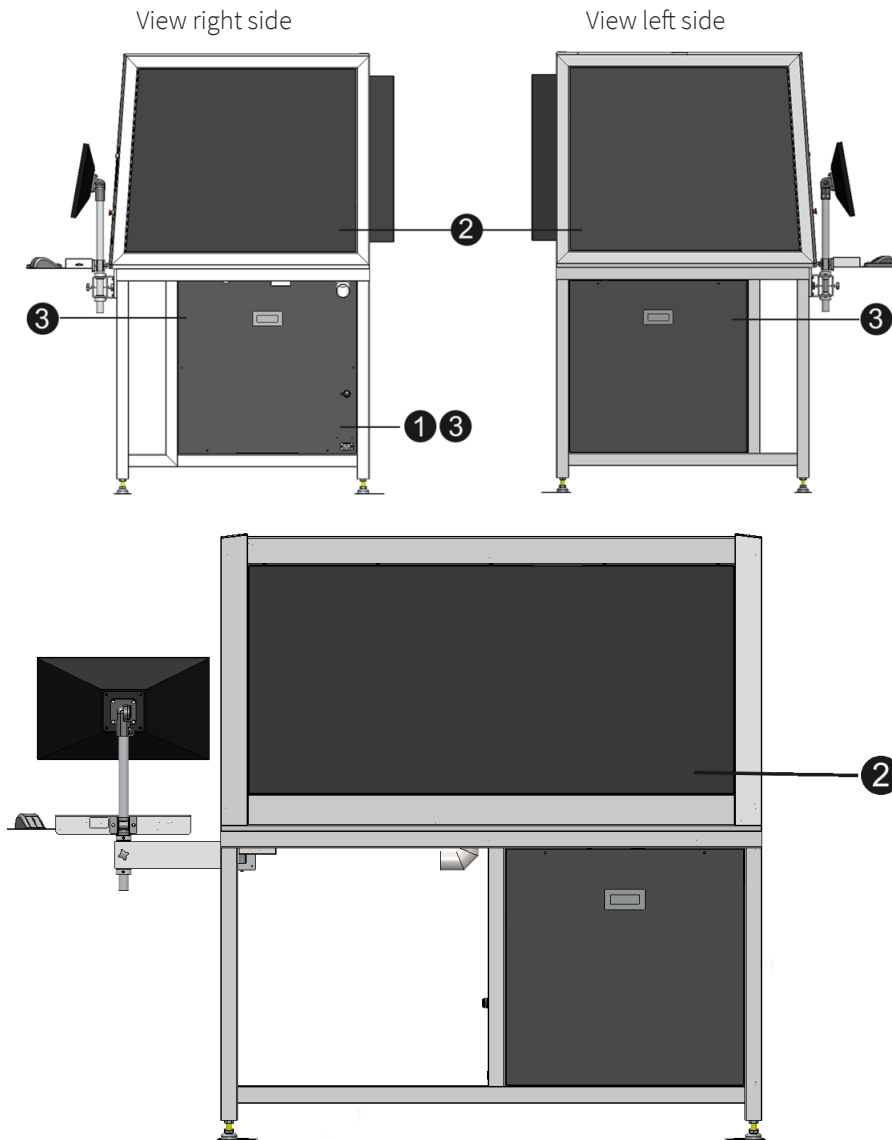

1 INPUT POWER  
100-240VAC 50/60HZ

2 **CAUTION**  
INVISIBLE LASER RADIATION CLASS 4  
WHEN OPENED AND  
SAFETY INTERLOCKS DEFEATED  
AVOID EYE OR SKIN EXPOSURE TO  
DIRECT OR SCATTERED RADIATION  
per IEC 60825 - 1:2015-07

3 **ACHTUNG !**  
Vor Öffnen des Gerätes ist  
der Netzstecker zu ziehen  
**ATTENTION !**  
Hazardous voltage inside  
Before opening disconnect mains

## 3.6 Secondary (indirect) hazards

### 3.6.1 Fire hazard



#### **Warning** **Fire hazard**

Fire hazard from gas and processing of inflammable materials.

- Do not operate the device without supervision.
- Keep CO<sub>2</sub> fire extinguisher ready at hand in the immediate vicinity of the device.

If a main laser beam comes into contact with inflammable material, e.g. paper, the latter may ignite, quickly leading to fire. Therefore, before switching on the laser and after deactivating the Standby-mode you must make sure that there is no inflammable material in the path of the laser beam.

Furthermore, gases formed beneath the material being processed may ignite, especially if the extraction requirements are not met. The risk of flaming is increased in case of insufficient care and cleaning as well.

Additionally, regularly control the air cooling system on your laser. In particular, the filters and ventilators should be checked regularly for proper function to avoid defects caused by overheating



#### **Warning** **Danger from flammable or explosive materials**

Class 4 laser radiation, as emitted by the built-in SpeedMarker FL, can ignite or explode materials. Among other things, it must be ensured that:

- the parameters are selected so that no excessive heating of the material occurs.
- the plant is monitored when necessary.
- dusts are safely extracted. No flammable residues or remnants can collect in the working area.

### 3.6.2 Gases, fumes and dust

Depending on the materials being processed and the parameters selected, laser processing may generate gases, fumes, aerosols or dust. Depending on the material, such by-products may be toxic. In individual cases, the reaction products may be electrically conductive dusts. If these enter electric systems, short-circuiting with personal injury and property damage may occur.

The operator is responsible for ensuring presence of a suitable extraction system and compliance with the relevant guidelines in order to protect persons and the environment. Find out about local guidelines.

The operator must also ensure that gases, fumes or dust do not settle on the processing lens. Any dirt accumulating on the processing lens can lead to loss of performance, poor processing results and damage to the device.

### 3.7 In case of emergency

#### WHAT TO DO IN THE EVENT OF MALFUNCTIONS

- In unusual operating conditions, open the lid to stop the machining process press the emergency stop button and switch off the machine.
- If necessary, disconnect the machine from the main power supply.
- Inform the laser protection officer and your supervisor.
- Repair work must only be carried out by Trotec Laser GmbH service technicians.
- In the event of a fire: Fight the fire with a CO<sub>2</sub> fire extinguisher as far as is possible without risk.



#### Notice

After a deletion, Trotec Technical Support must be involved before the system is put back into operation.

#### WHAT TO DO IN THE EVENT OF AN ACCIDENT, FIRST AID

- If eye damage occurs due to laser radiation, the casualty must present to an ophthalmologist immediately.
- First aiders must protect themselves.
- Disconnect the device from the power supply and secure it against restarting
  - Remove the key switch.
  - Unplug the power cable.
- Rescue the injured person from the danger area and provide first aid.
- Call an emergency doctor!

## 4 Technical Data

→ The technical data sheet can be found in the appendix of this manual.

### 4.1 Electrical requirements of the machine



#### Caution

Inadequate or inappropriate power sources can lead to machine damage and are not covered by any liability.

Verify that the electrical outlet is capable of providing the proper voltage, frequency and amperage required by the laser machine described in this manual.



#### Caution

Electrical noise, unstable power supply as well as voltage spikes in power supply can cause interference and possible damage to the electronics of the laser machine.



#### Notice

Use an individual circuit for the laser machine and the PC and an individual circuit for the exhaust system. Install your computer to the same circuit as the laser machine to prevent electromagnetic interactions.

Furthermore it is highly recommended that you use a overvoltage protection switch to protect your computer equipment.

If electrical power fluctuations, brownouts or power outages are a problem in your area, an electrical line stabilizer, UPS (Uninterruptible Power Supply) or backup generator are required. When installing any of these devices, ensure that they meet the electrical requirements of the laser machine.

### 4.2 Exhaust system requirements



#### Danger

##### **Danger of emission of toxic gases, vapors or dust.**

During laser operation, toxic aerosols may be produced.

- The laser system may be operated only with properly installed and operating exhaust system.
- Check with the material manufacturer for its toxic effect.



#### Caution

The laser may only be operated with properly installed and operating exhaust system. Damage to the system, caused by the use of not any exhaust system or improper extraction equipment, will not be covered by any liability.

The requirements for the exhaust system and recommended Trotec exhaust systems for standard applications depend on the working table installed in the machine.



### Notice

Connection has to be carried out by our Technical Support.

Observe instructions for operation and maintenance according to the operating manual of the exhaust system.

### TECHNICAL DATA OF THE CORRESPONDING EXHAUST SYSTEMS:

Exhaust system	Hose connection ø [mm] (inside diameter)	Volume flow [m <sup>3</sup> /h]	Pressure [Pa]
Atmos Nano	45	200	8500 (230V)
Atmos Cube (Atmos Compact)	80 / 80 (70 / 45)	250	8500 (230V) 5800 (115V)
Atmos Mono	70 / 70 / 45	320	8500 (230V) 5800 (115V)
Atmos Mono Plus	70 / 70 / 45	320	8500 (230V) 5800 (115V)
Atmos Duo Plus	70 / 70 / 45	(2x) 320	8500 (230V)
Vent Set 300	80	max. 1000	max. 2550
Vent Set 400	100	max. 1000	max. 3800
Vent Set 500	100	max. 1200	max. 7000

### REQUIREMENTS FOR THE EXHAUST SYSTEM:

Machine	Volume flow [m <sup>3</sup> /h]	Pressure [Pa]
SpeedMarker	320	8500

The monitoring point for flow rate and pressure is at the exhaust port at the laser machine. Pressure loss by hoses / pipes or filter parts of the exhaust system has to be determined and additionally calculated when selecting a proper exhaust system.

A powerful exhaust system keeps the lifetime of optics and mechanical components, the cutting quality and the laser power interacting with the workpiece from being impaired by fumes and dust accumulating in the machine.





### Notice

The exhaust power available for the application will be reduced by e. g. bends, small hose diameters and long hoses.

#### You should therefore note the following:

- Avoid bends.
- Keep hose as short as possible.
- Use hose diameters as large as possible.

Applications generating large amounts of dust or fumes may require a stronger exhaust system. Use of separate exhaust systems for head and table exhaust may also be necessary.

In this case it is absolute necessary to consult your distributor.

## 4.3 Connecting a cooling unit

The connection has to be carried out by a Trotec technician.

Follow the operation and maintenance instructions in the manual of the cooling system.



### Warning Dangerous electrical voltage

#### Wrong voltage can cause damage to the machine.

Do not operate the machine, if the mains voltage does not match the voltage required by the exhaust system, as this may cause damage to the machine.

Make sure that the mains voltage matches the voltage required by the exhaust system.

## 5 Machine overview

### 5.1 General overview

#### FRONT VIEW

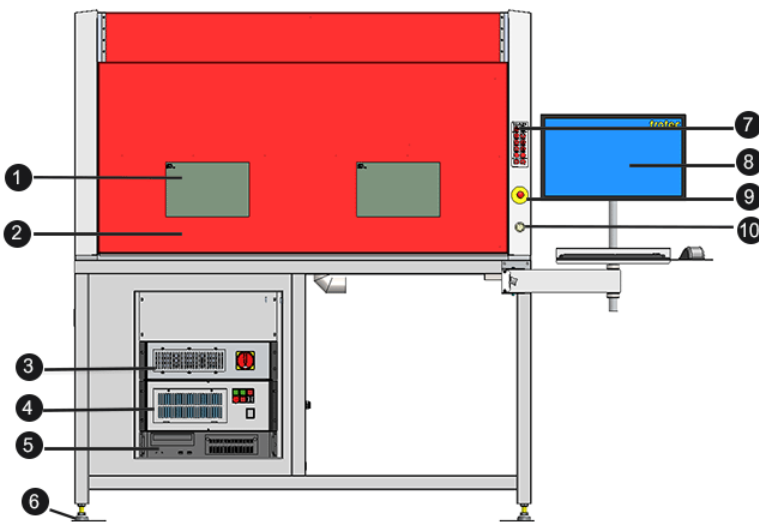

- 1 Safety glass
- 2 Safety door
- 3 Control rack
- 4 Laser rack
- 5 Industrial PC
- 6 Feet (rolls optional)
- 7 Keypad
- 8 Monitor, keyboard, mouse
- 9 Emergency stop button
- 10 Start button

#### BACK VIEW

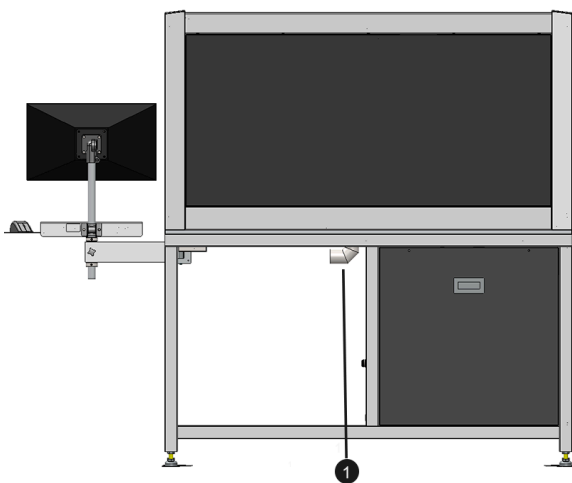

- 1 Extraction system connector

**SIDE VIEW RIGHT:**

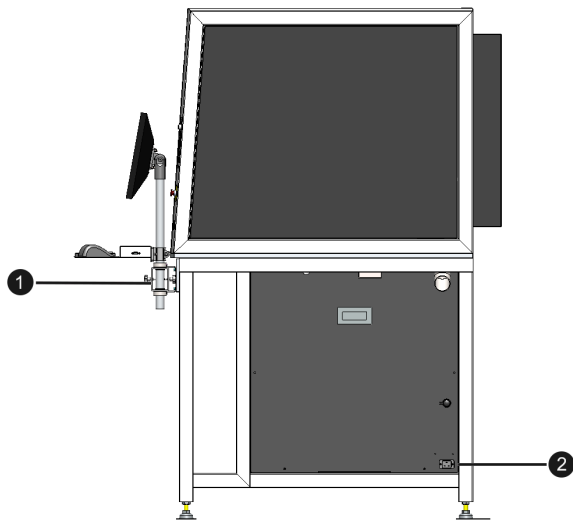

- 1 Swivel arm
- 2 Power supply connector

**SIDE VIEW LEFT:**

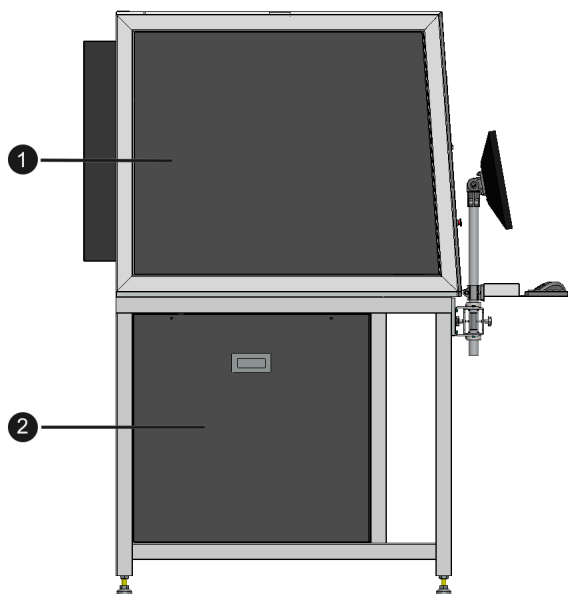

- 1 Protection cover
- 2 Cover

**SUPPLY CONNECTIONS**

The power cable can be connected via a cold-device plug connection.

Connect a suction hose with nominal diameter 45.

5.2 Machining area

**GENERAL AXIS DESIGN**

Each axis system consists of a linear servo axis with precision.

z- and y-axis with tandem-axis and the x-axis have two limit switches and two mechanical stops.

## Machine overview

---

The laser head is mounted above the adapter plate on the x-axis.

The x-axis is mounted on the z-axis.

The y-axis is a movable table where objects can be placed.

The processing area contains the axis system and is closed during the marking process.

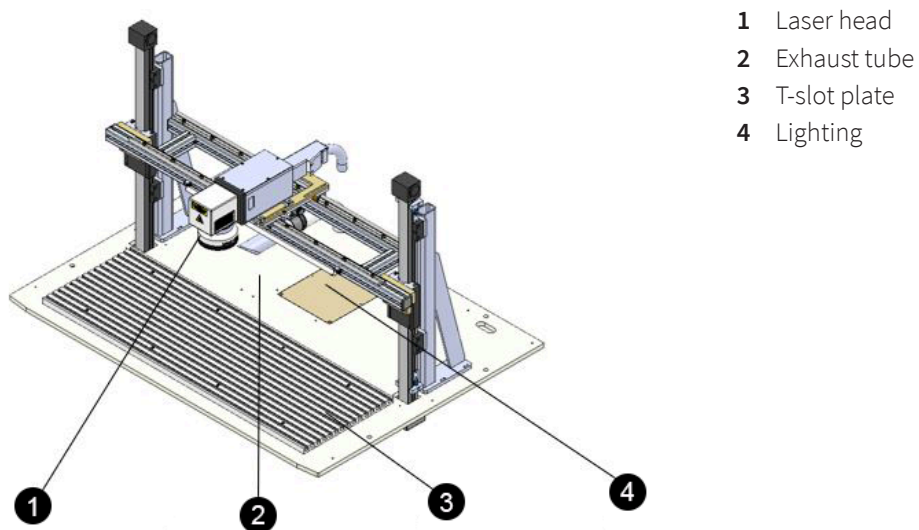

### SOFTWARE CONTROLLED Z- AND X-AXIS

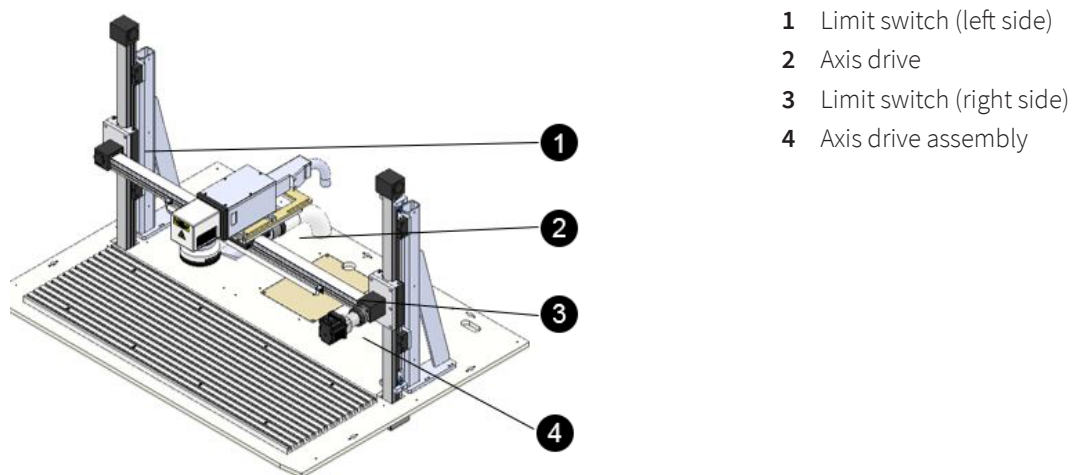

## SOFTWARE CONTROLLED Z-, X- AND Y-AXIS

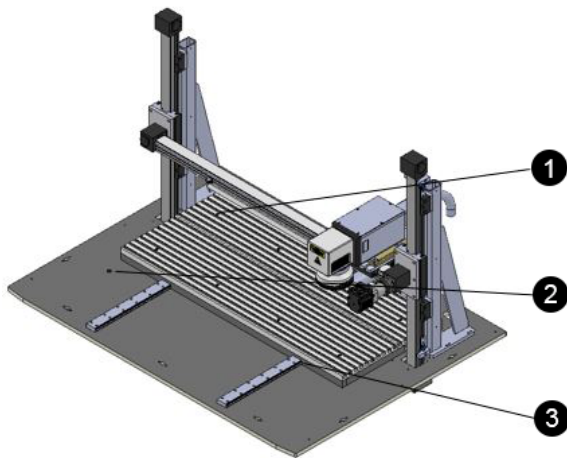

- 1 Limit switch (at the back)
- 2 Limit switch (in front)
- 3 Axis system

### General structure of the axes

- The z-axis consists of a belt axis.
- The z-axis is designed as a single axis.
- The z-axis is driven by a precise servo motor.
- The z-axis is limited by two electrical limit switches and a mechanical stop.

## 5.3 Control elements

### The electrical and electronic controls are housed in three 19" racks:

- System control
- Laser control
- Industrial PC

### 5.3.1 System control

The system control takes over the control of the safety gate, the automatic sequence and the safety.

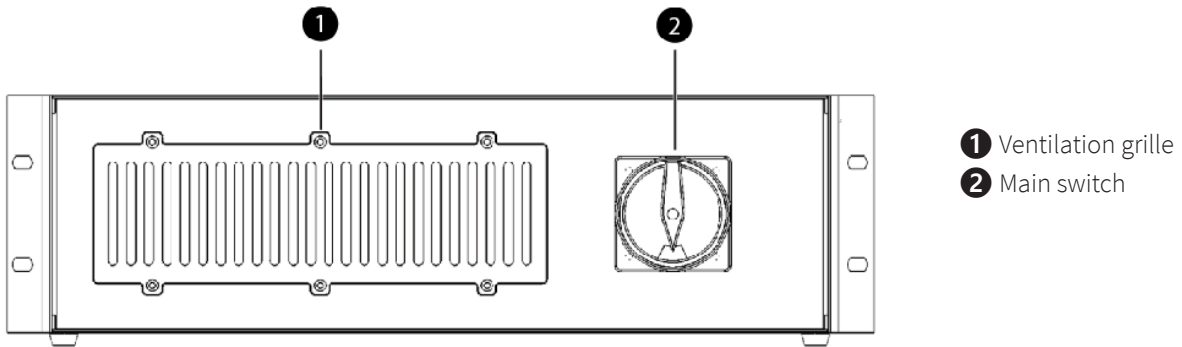

### 5.3.2 Laser rack

#### LASER RACK

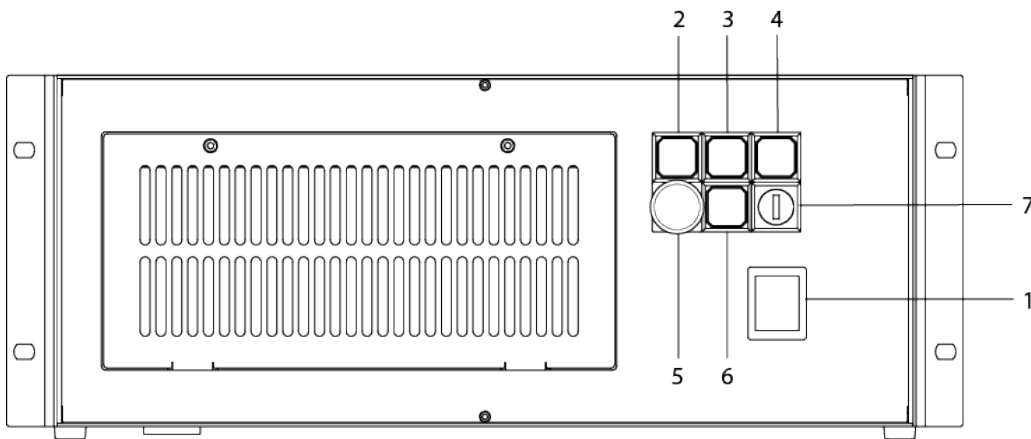

Number	Description	Types
1	Main switch	toggle switch
2	System ready	control lamp
3	Shutter	control lamp
4	Laser busy	control lamp
5	Emergency stop button	switch
6	Error reset	button
7	Key switch	switch

### 5.3.3 Industrial PC

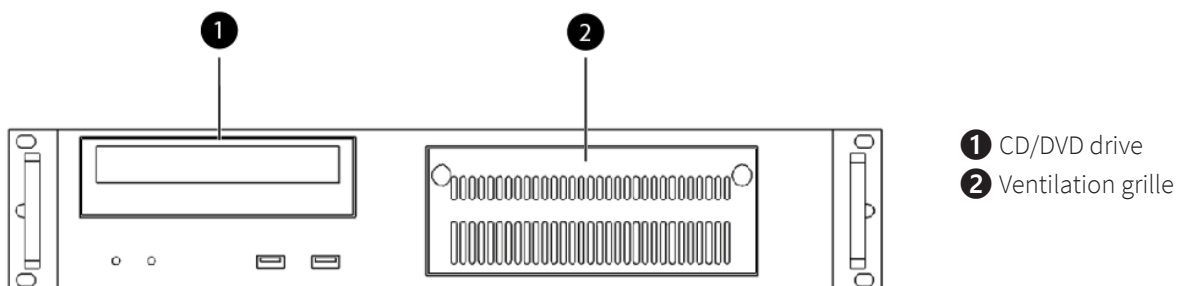

- ❶ CD/DVD drive
- ❷ Ventilation grille

## 5.4 Safety devices

### MAIN SWITCH

#### Base cover on the right:

- When the main switch is operated, the entire system is de-energized.
- Laser is off.

#### ❶ Main switch

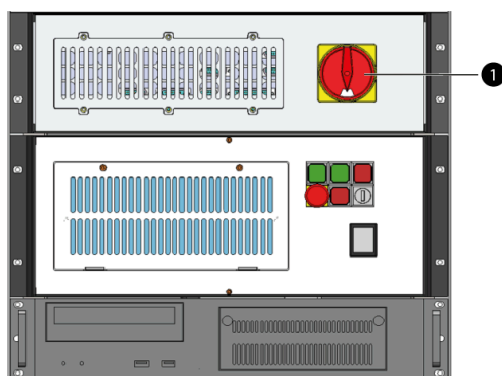

### EMERGENCY STOP BUTTON

1. On the front.
2. On the laser rack.

Task of the emergency stop device:

First priority: prevention of danger to operating personnel.

Second priority: prevention of damage or destruction of machine or material.

- Immediately switch off the circuit.
- Laser beam is interrupted by the shutter.

- All movements are stopped.
- The triggering of the emergency stop function is indicated by a fault message.

### EMERGENCY STOP ACKNOWLEDGMENT - SEQUENCE

Variant 1:



- ❶ ON button
- ❷ Emergency stop button

1. **Unlock emergency stop button**  
Turn emergency stop button
2. **Acknowledge emergency stop**  
Press the ON button on the keypad
3. **Acknowledge laser fault**  
Confirm ON button on the keypad

Variant 2:

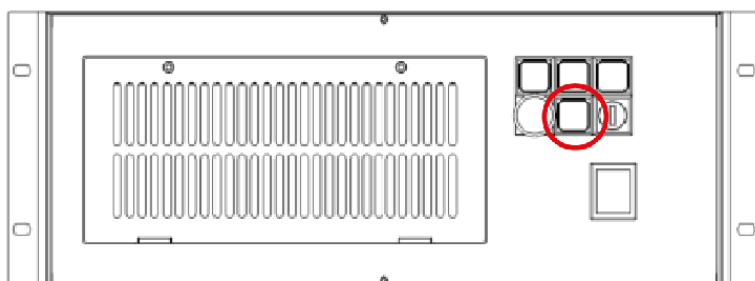

Press the error reset button on the laser rack.



## SAFETY SWITCH ON THE SAFETY DOOR

### Observation window:

The light blue observation window in the front door is made of a laser protection filter according to DIN EN 201, which is made of a special material that is adapted to the laser type and absorbs the laser radiation. If the window is damaged, it must be replaced.

### Safety shutter in the laser:

If a safety circuit in the laser system is open, the safety shutter in the laser closes immediately. For safety reasons, this shutdown follows via safe components. This interruption in the laser is mechanical. An error message is output.

### Cladding panels

Cover plates protect from laser light.



### Warning Laser

All protection plates must be mounted all times.

### 6 Before commissioning

- Read the operating manual and ensure it is accessible at all times.
- The ambient temperature must be between +15 °C and +25 °C (59 °F and 77 °F) and not exceed the relative humidity of 45-65% (non-condensing). Non-observation leads to damage.
- A laser system consists of high quality electrical and optical components. Mechanical stresses, vibrations and impacts must always be avoided.
- If the system has been subject to significant temperature variations, it must be brought back to room temperature before being commissioned.
- Sufficient air must be supplied to the 19 inch module of ventilated systems. The accumulation of heat due to covered ventilation slots or filter pads can damage the system.
- Assemble the device at the point of installation according to the instructions.
- The operating personnel must read and understand the operating manual, in particular the chapter on "Safety notes". It is recommended that the operator compiles with inhouse instructions regarding safety and operation and that the receipt of these instructions/operating manual and the participation in briefings/training courses is confirmed in writing.
- Laser marking may generate gases, fumes and other reaction products on the surface of the material. The operator must therefore use an effective extraction system.

#### 6.1 Unloading, inspection and reporting faults

##### **In the event of transportation damage or incomplete delivery:**

- Record all details in writing immediately.
- Note all claims on the transportation documents.
- Photograph any damage.
- Send report to Trotec Laser GmbH.

##### **Nach dem Entladen:**

- Remove all transport packaging.
- Check the delivery for completeness.
- Inspect the machine and machine components for transportation damage.

## 7 Transport and Storage

### 7.1 Transport conditions

- When transporting outside, always transport in a covered vehicle or one with sufficient weather-proofing.
- Protect the machine against transportation damage using straps and inserts, and leave sufficient distance between other transported items.
- Ambient temperature for transportation:  
minimum temperature 10°C  
maximum temperature 40°C
- Handle the machine and machine components with care.
- Do not place any heavy loads on the machine or machine components.
- Avoid heavy impacts.
- Take particular care when transporting electronic components.

#### Transport conditions

Transport temperature (ambiente temperature):	-10 °C to +40 °C (14 °F to 104 °F)
Relative humidity:	Maximum 70%, non-condensing

- Avoid high temperature fluctuations.

After unpacking the laser system from the wooden packaging, the edge protection on the front side of the machine and the foam protection for the door mechanism must be removed. The foam protection is located above and below the door weight.

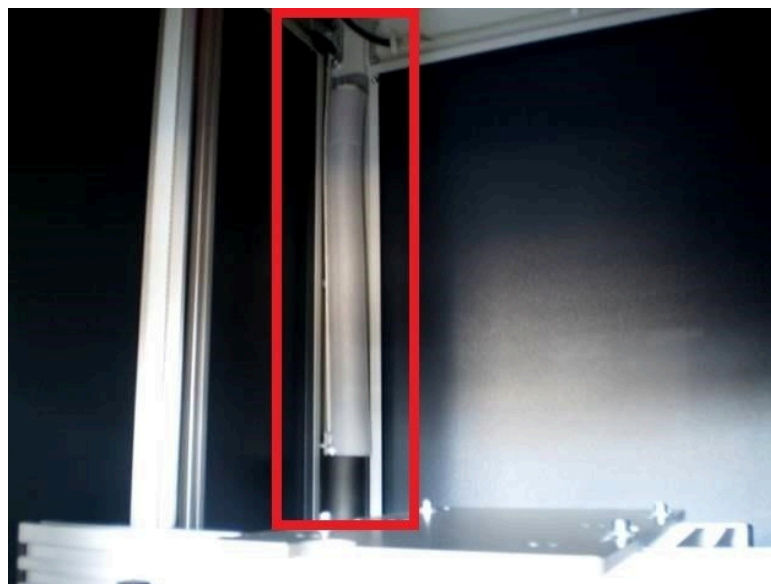

### 7.2 Storage conditions

- Store the machine and machine components in a dry location.
- Protect the machine and machine components against scratches.
- Take particular care when packing away electronic components.
- When storing for a long period, preserve bare metal parts (e.g. apply oil).

#### Storage conditions

Storage temperature (ambiente temperature):	0 °C to +30 °C (32 °F to 86 °F)
Relative humidity:	Maximum 60%, non-condensing

- Avoid high temperature fluctuations.

### 7.3 Place of storage

Storage room or boxed with sufficient weatherproofing. The storage location must be free from corrosive elements, fumes and flammable materials.

### 7.4 Transport inspection and reporting of defects



#### Caution

The lens unit cover should not be removed until after installation. The optics are high-quality optical components whose perfect condition is necessary for an optimal marking result.

- Immediately after receipt inspect the delivery to ensure that it is complete and has not suffered any damage.
- If any transport damage is visible, do not accept the delivery, or accept it only with reservation.
- Record the scope of the damage on the transport documents or delivery note.
- For all defects that are not discovered upon delivery, be sure to report them as soon as they are detected, since damage claims must be filed within a certain period, as mandated by law.

## 8 Setup and installation

### 8.1 For your safety



#### Notice

The setup has to be carried out by Technical Support.

### 8.2 Temperature and humidity

#### Ambiente conditions

Operating temperature (ambiente temperature):	+15 °C to +35 °C (59 °F to 95 °F)
Relative humidity:	max. 60%, non-condensing

- If the system has been exposed to large temperature fluctuations, it must first be brought back to room temperature before commissioning.

#### ENVIRONMENTAL CONDITIONS

- Provide sufficient illumination at the workplace.
- Ensure a dust-free environment (II° according to IEC60947-1).
- Shielding from EMC.
- Freedom of interfering electrical installations, hoses and pipe lines.
- Power supply free of fluctuations.

### 8.3 Installation location

#### INSTALLATION LOCATION

##### The installation location must:

- Have a stable power supply.
- Be vibration free.
- Have sufficient air supply for the laser rack and PC.

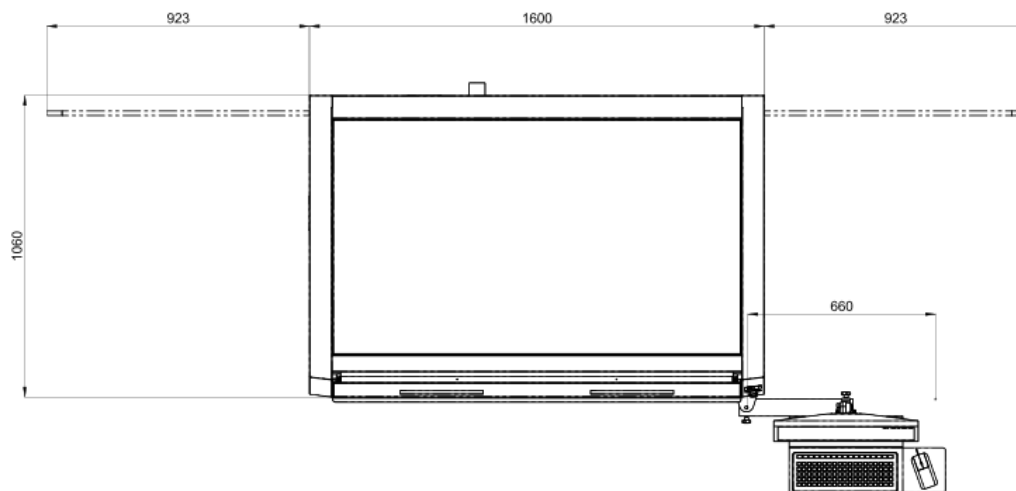

### 8.4 Electrical installation

#### 8.4.1 Overview laser rack interface (back side)



##### **Notice**

Before the laser marker can be put into operation, the external safety circuits and the external start and stop signals must be connected.



##### **Caution**

When making these connections, the operator must ensure that all safety circuits comply with the respective valid national standards and guidelines for the use of laser devices. Otherwise the device may cause personal injury or material damage.

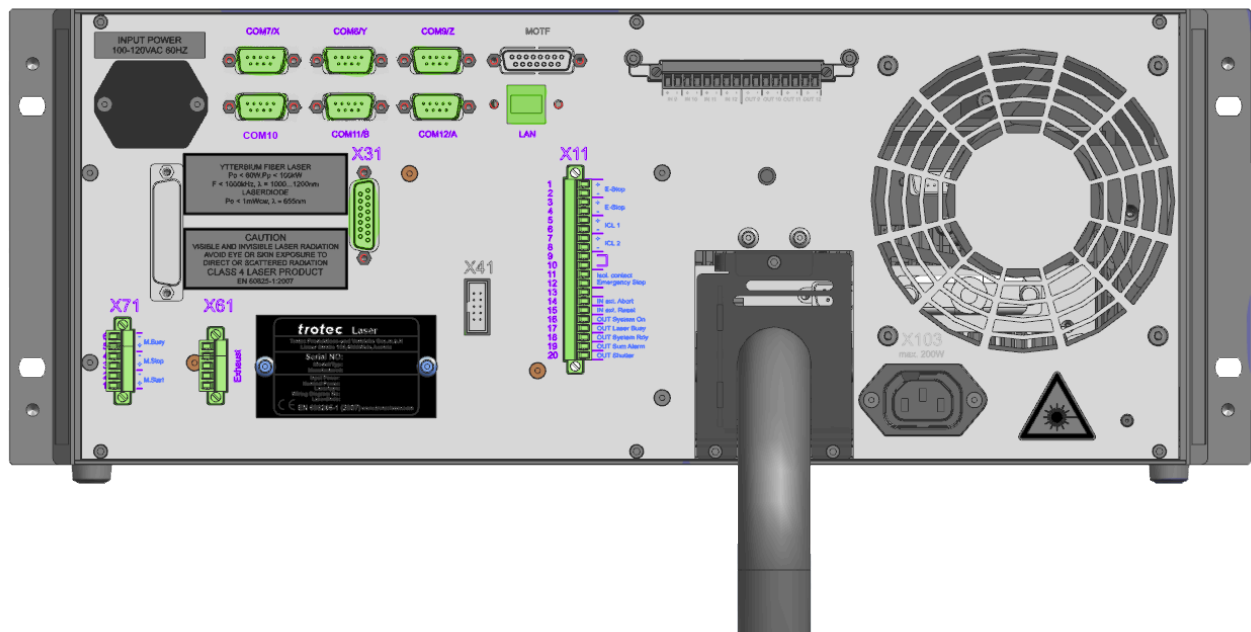

The following connectors are available on the laser rack:

### X11 – Safety circuit (Emergency stop button / interlock safety switch / external messages)

The X11 connector enables the connection of external safety circuits, additional emergency stop circuits and external warning lamps.



#### Warning

The digital 24V inputs should only be controlled by isolated contacts with the 24V pin 13 on X11. The input of signals with any other reference potential could result in damage to the respective inputs.

### X31 – External panel

The connector X31 may be used to connect an external control panel such as that located on the front of the laser rack.

If no external panel is connected, the supplied connector must be used with the bridging devices.

### X61 – Exhaust system

This connector is used to control, start and stop a Trotec extraction unit. Only use the original cable supplied.

### X71 – Start / Stop

The X71 connector may be used to send start and stop signals via an external controller or receive a signal from the laser. The pin configuration is provided in “Interface Pin Configurations”

“Busy” is a laser output which can be set as required using a script.

“Stop” is an external input used to interrupt all running laser programs immediately. It is not necessary to monitor these inputs in a script.

“Start” is an external input which may be monitored in the software in order to trigger a marking process. If the monitoring of the signal is not active within a script, the input will have no effect on the program sequence.

## Setup and installation

---

For the “Start” and “Stop” Signal external 24VDC are needed.

### **COM7/X**

Connection X-Axis

### **COM8/Y**

Connection Y-Axis

### **COM9/Z**

Connection Z-Axis

### **COM10**

Reserved

### **COM11/B**

Connection B-Axis

### **COM12/A**

Connection A-Axis

### **LAN**

Connection between PC and Laserrack



#### **Warning**

The maximum load of each of the digital 24V outputs on the interface is 100mA. A short circuit of the outputs must be avoided as it will damage the respective inputs.

The system is equipped with an additional Input/Output option.

#### **With this option you can**

- feed the software with e.g. start, stop or status signals.
- activate signals by the software for e.g. warning lamps or relays.



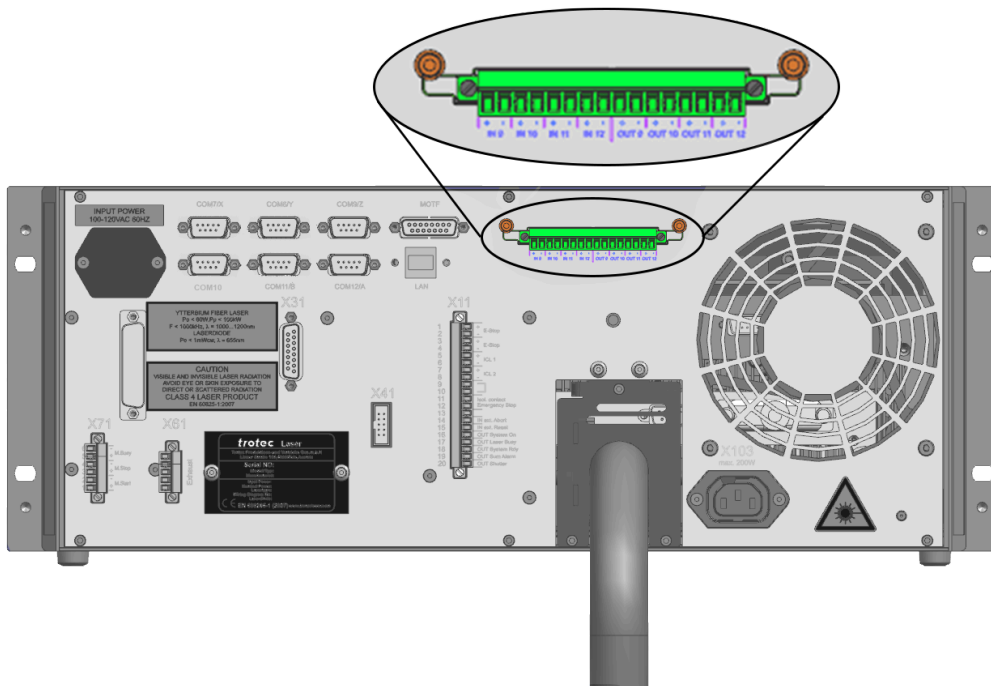

- The inputs have to be provided with a 5V - 24V potential.
- For “ON”, the first PIN (e.g. PIN1) has to be provided with 24V and the second PIN (e.g. PIN2) has to go to ground to ensure the potential.
- The software closes the contact to let the signal from the first PIN (e.g. PIN11) through to the second PIN (e.g. PIN12).
- The outputs sections provide potential free relays contacts.
- The addressing is done by the software. For details please refer to the software manual.

**SPECIFICATION:**

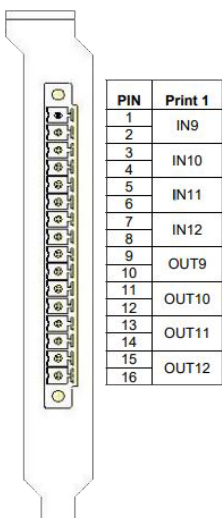

- Maximum number of input signals: 1 per print
- Maximum voltage on output: 24V AC or DC
- Maximum current on each output: 1A

## APPLICATION EXAMPLES

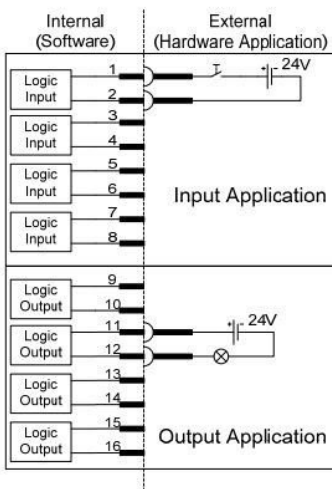

Input with switch and external 24V source at input "IN9".

Supply of a lamp with 24V by activating "OUT10".

### 8.4.2 Overview PC interface (back side)

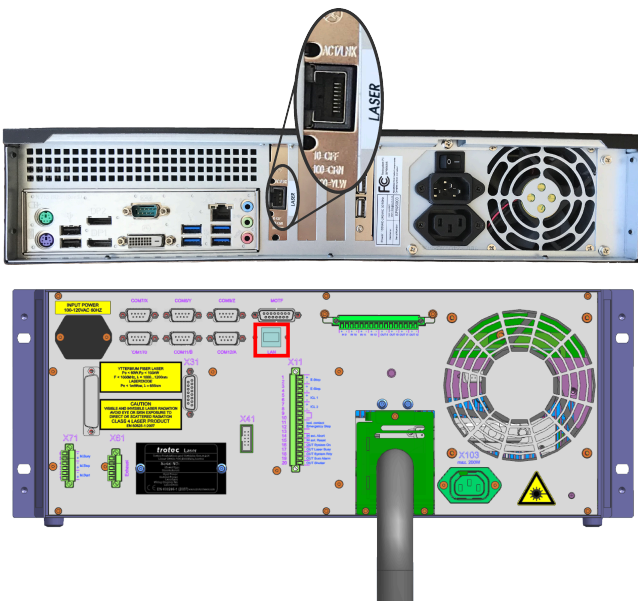

The machine is connected to the Ethernet via a cable connection from the LAN interface on the rear of the PC rack to the LAN interface on the laser rack.

### THE FOLLOWING IP ADDRESSES ARE RESERVED:

192.168.0.3	192.168.0.10	192.168.0.13	192.168.0.16	192.168.0.19
192.168.0.5	192.168.0.11	192.168.0.14	192.168.0.17	192.168.0.50
192.168.0.7	192.168.0.12	192.168.0.15	192.168.0.18	

### 8.4.3 Mains connection

Laser rack and PC have a cold device socket on the rear for the cold device cables supplied.

The configuration of the laser rack is given on the type plate or on the warning label above the IEC connector.



#### **Warning Dangerous electrical voltage**

The laser rack is fitted with different main fuses depending on the configured supply voltage:

115V AC	-	1 x 6.3 A "T" speed/time-delay
230V AC	-	2 x 4 A "T" speed/time-delay

The main fuses are located behind the cover, immediately adjacent to the IEC connector.

The same main fuse is used on the PC for all mains voltages.

# 9 Operation

## 9.1 Installation inspection

The following points must be checked to ensure correct installation:

- Correct power supply connections and fuses.
- Complete and correct mechanical and electrical installation.
- Check that the mechanical and electrical installation is complete and correct Input voltages.
- Checking the purity of the optical components (free of dust and dirt).
- Remove the protective cover from the focusing lens.
- Check the environmental conditions against the technical specification.
- Observe laser safety regulations.
- Check compliance with all laser safety measures. The system may only be switched on if all precautions have been taken to comply with the laser safety have been checked. by an authorized person and found to comply with the standards.

## 9.2 Marking software

The marking software is included on an accompanying data medium.

For information on using the software, please read the accompanying software manual.

### 9.3 Control elements



- ❶ LEDs
- ❷ Keypad
- ❸ Emergency stop button
- ❹ Start button

#### LED



LED	Status	Description
POWER	green	Power supply is switched on
ON	green	Laser control is switched on
LASER	green	Laser is active
ERROR	red	Interference, not yet acknowledged
AUTO	green	Automatic mode is active

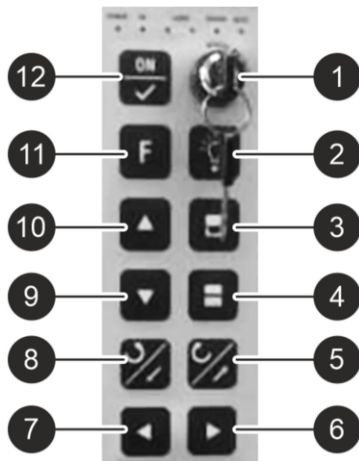

- |    |                      |  |
|----|----------------------|--|
| 1  | Key switch           | Selection of manual or automatic operation               |
| 2  | Button               | Lighting in the machining area                           |
| 3  | Safety door open     | Move safety door upwards                                 |
| 4  | Safety door closed   | Move safety door down                                    |
| 5  | Button backward (Y)  | Move laser to the back                                   |
| 6  | Button right (X)     | Move laser to the right                                  |
| 7  | Button left (X)      | Move laser to the left                                   |
| 8  | Button forward (Y)   | Move laser forward                                       |
| 9  | Button downwards (Z) | Move laser down  |
| 10 | Button up (Z)        | Move laser upwards                                       |
| 11 | Function key F       | Switch between x- and y-axis modes                       |
| 12 | Button ON            | Acknowledge after switching on, emergency stop and fault |



## Information

The functions for moving the laser and moving the safety door are only active in the operating mode "Manual".

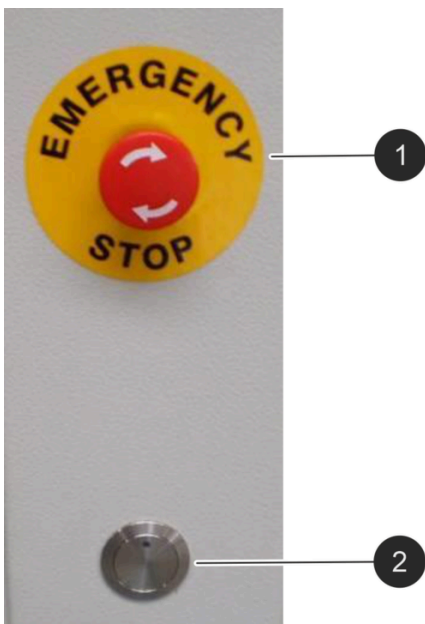

- 1 Emergency stop button
  - press in case of danger.
  - Power supply of the PC remains.
- 2 Automatic start button
  - Starting processing in automatic mode.

## 9.4 Manual operation

### MANUAL CONTROL OF SAFETY DOOR



Button: Safety door open



Button: Safety door closed

### SOFTWARE CONTROLLED X-, Y- AND Z-AXIS

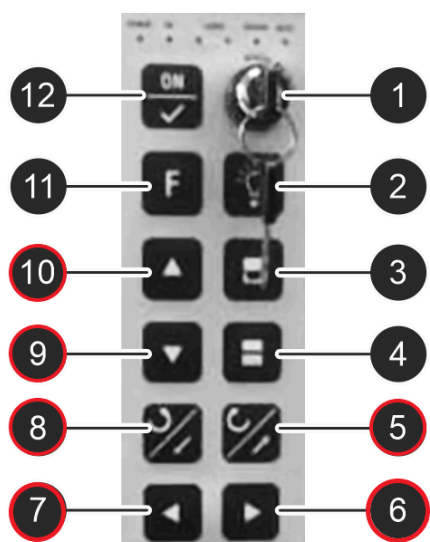

- (5) y-axis back, moving the y-axis backward.
- (6) x-axis right, traverse the x-axis to the right
- (7) x-axis left, move x-axis to the left
- (8) y-axis forward, move y-axis forward
- (9) z stroke down, traverse the z-axis downward
- (10) z stroke up, move the z-axis upwards

- The axes are limited by limit switches.
- When moving, be careful that the lens does not collide with the workpiece.
- After switching on the SpeedMarker or after an emergency stop, a reference run must be carried out. This can either be started manually in the marking software or is automatically queried when the software is started.
- In automatic mode the axes are controlled from the laser PC.



#### Caution

Risk of crushing when moving the axes.

## 9.5 Emission indicator

The laser system is equipped with an emission indicator.

This is indicated by a separate display on the marking head and/or by a luminous control lamp (shutter) on the laser rack.

### MEANING OF THE SIGNAL COLORS

---

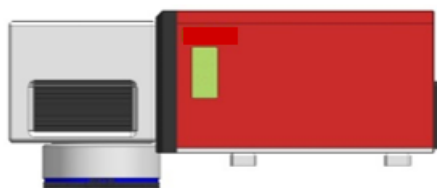

**Emission indicator off** - Device de-energised.

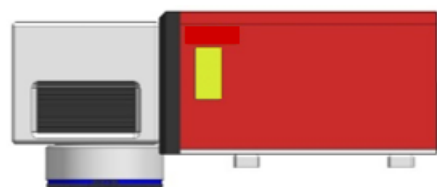

**Emission indicator status yellow** - shutter is closed, no laser power output.

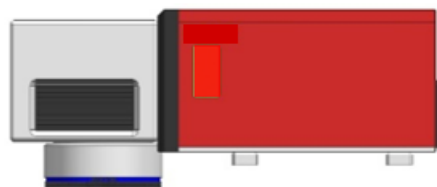

**Emission indicator status red** - shutter is open, output of laser power possible.



#### Warning Laser

If the device is switched on or the safety shutter is open there is a danger of laser radiation.

- Pay attention to the emission display.
  - Do not open laser marking head.
- 

## 9.6 Focusing



### Notice

It is absolutely essential to maintain the correct focal distance for every laser marking process. Only when in focus will the laser beam achieve the power density necessary for permanent and clearly legible marking.

Prior to any marking it is therefore necessary to set the correct focal distance between the marking head and the workpiece. An incorrect focal distance is the most common cause of poor or even indistinguishable markings.

The focal distance **(A)** is measured between the lower edge of the working galvo head **(B)** and the upper surface of the workpiece **(C)**. The correct focal distance depends on the lens used (focal length).



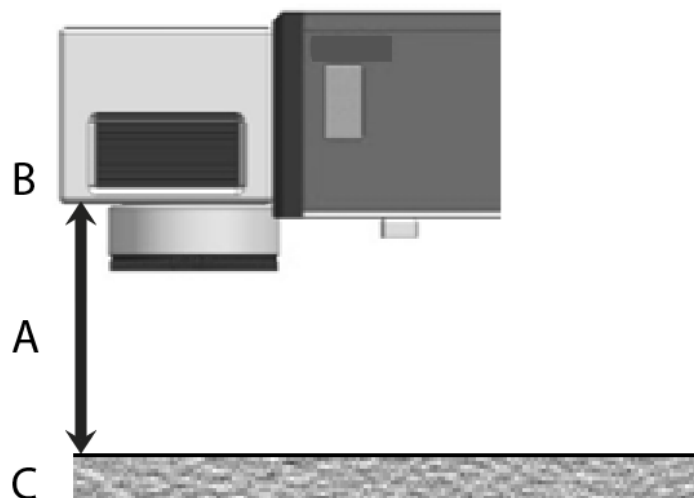

## CR

Focal length	Working distance (A)
F = 100	154,0 mm
F = 160	215,0 mm
F = 210	271,5 mm
F = 254	322,0 mm
F = 330	391,5 mm
F = 420	501,5 mm

## 9.7 Options

### 9.7.1 SpeedMarker “DS” Dynamic Shifting

The SpeedMarker DS enables very fast and precise focusing without mechanical movement of the marking head. The optical z-axis built in for this purpose is controlled via the software using the “Focus Shift” function.

The SpeedMarker DS is available in the “D160” and “D254” versions.

The working fields of the SpeedMarker DS result depending on the maximum desired z-stroke.

## WORK VOLUME

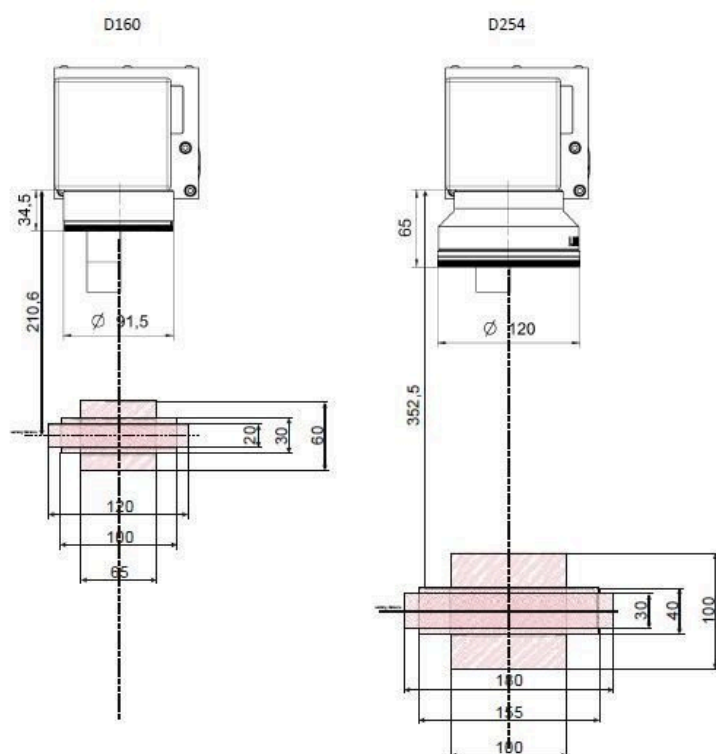

### Information

Further and detailed information on the use of the functions can be found in the software manual.

### 9.7.2 3D-Projection/Virtual Rotary

In addition to the Focus Shift function, it is possible to activate the “3D-Projection” option for xyz-axis systems by means of a license key. This allows various 3D shapes to be labeled flexibly and easily.

### 9.7.3 SpeedMark Vision - Smart Adjust

The Smart Adjust option is an integrated camera system for user-friendly and highly precise positioning of markings directly on the component by superimposing a camera image on the operator interface.



### Information

For further information, please refer to the appendix “Datasheet Smart Adjust” or the manual “SpeedMark Vision Smart Adjust”.

## 10 Maintenance

### 10.1 Safety notes



#### Caution

Before any maintenance work takes place, ensure that the power supply has been switched off and the system is de-energised.



#### Notice

All maintenance work must be carried out according to the safety regulations.

In order to ensure the maximum availability and lifetime of the system, we recommend you regularly check the filter system and ventilation and keep the surrounding area clean. Before switching on the system, make a visual inspection of the lenses.

### 10.2 Changing of the laser source filter mat

This laser system is equipped with air cooling. A filter mat is used to protect the electronic components from dust and impurities in the ambient air. This filter mat should be checked and replaced at regular intervals to ensure an optimal cooling situation.

The filter pad is located behind the ventilation slots on the front of the laser rack or on the Pc.

Filter pad on the laser rack:

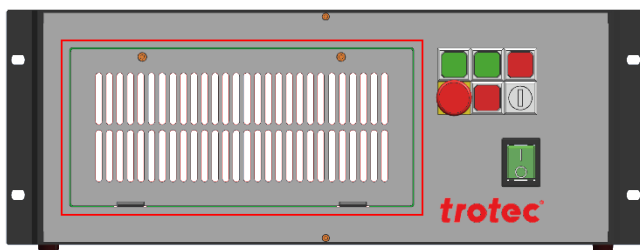

1. Cover of the filter pad.

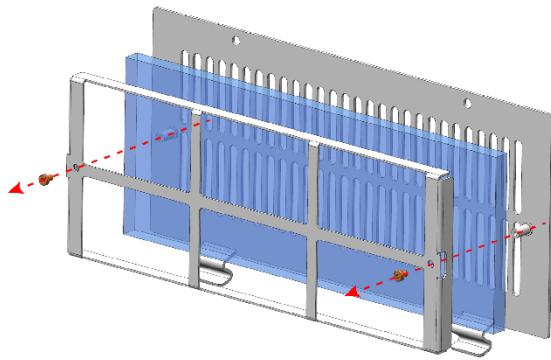

2. Remove both screws and open the cover. Change the filter pad.

### 10.3 Cleaning the optics

This system is fitted with high quality optical components, which under normal operating conditions are maintenance free for their lifetime. However, it may be necessary to clean output lenses, e.g. the scanner flat field lens (f-theta objective) if it becomes covered in dust or fumes.



#### Notice

Never touch the optical components with your fingers! Oily or dirty hands may damage the lens surfaces.

Do not use any tools or hard objects to clean the surfaces. Scratches cannot be repaired.

Laser optics are highly sensitive and their surfaces are not as hard as traditional glass. They can also be easily damaged by cleaning. It is therefore necessary to ensure that any dirt is removed using a suitable suction device and that the surrounding area is cleaned regularly.

Small bellows should be used to remove dust.



#### Notice

Do not use compressed air as it contains small quantities of oil and water.

To remove larger pieces of dirt, only use a lens cleaning cloth with high proof (at least 98%) alcohol.



#### Notice

Do not dip the cleaning cloth in the cleaning solution. This contaminates the solution and makes it unusable. Place drops of the solution on the cloth!

Apply the cleaning solution carefully in order to avoid scratching the surface of the lens.

Do not wipe the lens with a dry cloth. Do not touch the reverse side of the cloth. Dirt and sebum on the fingers can be transferred to the lens by the cloth and cause damage.

Distribute the cleaning fluid carefully using small circular motions. Start at the center of the lens and move outwards to the edge. Keep moving the cloth until the entire surface is clean.

Do not exert any pressure on the lens.

## 11 Troubleshooting

This chapter should assist maintenance personnel with the identification and resolution of operational faults based on error messages and symptoms.



### Danger

Maintenance and repair work should only be carried out by Trotec Laser GmbH or one of its authorized personnel under observation of the safety regulations.

### 11.1 Error, cause and remedy

Problem	Possible cause	Remedy
<b>Error message on loading the program.</b>	Plug or cable installed incorrectly.	Check the plug and cable are installed correctly.
	Laser power supply switched off.	Turn on main switch.
	Software not installed correctly.	Re-install software.
	Software terminated irregularly.	Restart computer.
<b>Laser will not switch on.</b>	Plug or cable installed incorrectly.	Check the plug and cable are installed correctly.
	Laser power supply switched off.	Turn on main switch.
	Faulty fuse in laser power supply.	Replace fuse.
<b>Status lamps on marking head remain green.</b>	safety circuit not closed.	Check safety circuit If no safety circuit is connected, use bridging connector X11.
<b>No laser beam.</b>	Laser not in focus.	Check working distance.
	Shutter closed.	Open shutter - if not possible check safety circuit.
	Incorrect laser parameters.	Check the parameters in the program. Use suitable parameters for the material and application.
<b>Insufficient laser output.</b>	Laser not in focus.	Check working distance.
	Incorrect laser parameters.	Check the parameters in the program. Use suitable parameters for the material and application.
<b>Missing symbols.</b>	Focusing lens dirty.	Clean focusing lens.
	Surface of the material dirty.	Clean material surface.
<b>Other faults.</b>		Contact Technical Support.

### 11.2 Possible error messages

Below is a list of possible errors which may be detected by the system. These will appear in the software as messages on the display.

The Reset signal (X11) or the reset button on the laser rack are used to acknowledge an error. In order for the system to be reset, the error or the corresponding input signal must be acknowledged.



#### Warning

System errors which cannot be reset or which indicate a hardware error should only be resolved by Trotec Laser GmbH trained service personnel.

Error message	Cause
Card off line.	Software has lost connection to the TLC2 controller
Scanner not connected.	No connection to the galvanometer scanner.
Scanner X error.	The X-axis of the galvanometer scanner has identified an error.
Scanner Y error.	The Y-axis of the galvanometer scanner has identified an error.
Signal cable not connected.	No connection to the marking head.
External abort.	External abort signal identified on X11.
External stop.	External stop signal identified on X11.
Voltage error (15V).	+/- 15V power supply not functioning correctly.
Voltage error (24V).	24V power supply not functioning correctly.
Laser power supply error.	Faulty laser source power supply.
Shutter error.	Shutter has not reached intended position.
Cover connector opened during marking.	ICL1 and ICL2 were opened during the marking process .
External sum alarm.	External error signal identified on X11.
System locked by key switch.	Key switch on laser rack locked.
Laser temperature.	Laser source overheated.
Laser power.	24 V power supply outside the permissible tolerance zone.
Laser not ready for emission.	e.g. key switch not activated.
Laser back reflection.	Back reflection of the laser beam.
Laser system error.	Laser power supply voltage is too high or too low.
Emergency stop button.	Emergency stop button activated.
Error.	+/-15V monitoring.
	24V laser monitoring.
	24V monitoring.
	Shutter temperature.

Error message	Cause
	Required shutter position.

### 12 Contact details

#### **TECHNICAL SUPPORT**

In case of questions, contact our experienced Technical Support in your local area.

For global service contact numbers and further information please see our website, section "Support":

**[www.troteclaser.com](http://www.troteclaser.com)**

When calling, please make sure that the machine is in your immediate vicinity, and that you have the following information ready (see response form):

- At which working process did the problem occur?
- What you have done so far to correct the problem.
- Serial no (see type plate).
- Error code.

#### **LOCAL OFFICES / SALES**

Our store locator and detailed information on our offices in your area can be found on our website in section "Contact", "Local Office": **[www.troteclaser.com](http://www.troteclaser.com)**

#### **TECHNICAL DOCUMENTATION**

For feedback or to suggest changes to this manual, contact:

Technical documentation: +43 (0) 7242 239 - 7000

E-Mail: **[technical.documentation@troteclaser.com](mailto:technical.documentation@troteclaser.com)**



## 13 Disassembly



### Warning

#### Danger of injury when disassembling the machine.

There is danger of injury when disassembling the machine.

Always wear suitable protective clothing (e.g. safety goggles, safety shoes, safety gloves).



### Warning Dangerous electrical voltage

#### Electric current.

The machine must be disconnected from the main power supply.



### Notice

- Always use suitable tools to disassemble the machine.
- Mind the springs.
- Follow chapter "Disposal".

### PROCESS:

1. Remove all workpieces from the system.
2. Turn the key switch to switch off the machine.
3. Switch off the main switch at the back of the machine.
4. Remove the exhaust system.
5. Disconnect all cables at the back of the machine.

### 14 Disposal



#### **Disposal**

##### **Do not dispose of the machine with domestic waste!**

Electronic devices have to be disposed of according to the regional directives on electronic and electric waste disposal.

In case of further questions, please ask your supplier.

In case of disassembly, use suitable tools to dismantle the unit into individual parts. Sort the individual parts and have them disposed of professionally. Legal regulations must be adhered to.

15 Appendix

# EC-Declaration of Confirmation

According to Machine Directive 2006/42/EC, Annex II 1. A

# trotec

## Manufacturer:

Trotec Laser Automation GmbH  
Planckstr. 12  
88677 Markdorf  
Germany

## Authorized person to compile the technical files:

Trotec Laser Automation GmbH  
Planckstr. 12  
88677 Markdorf  
Germany

## Description and Identification of the machine:

Product description	Laser engraving system
Model name	SpeedMarker 1600
Serial number	S16X-XXXX
Machine group	8059
Function	System for laser engraving

## It is declared expressly that the machine fulfills all of the following applicable EC directives and regulations:

2006/42/EC	EC Machine Directive 2006/42/EC
2014/30/EU	Directive 2014/30/EU Electromagnetic Compatibility

## Reference to the harmonized standards in accordance with article 7 (2):

ISO 12100:2010-11	Safety of machinery – General principles for design – Risk assessment and risk reduction( ISO 12100:2010 )
ISO 13849-1:2015	Safety of machinery – General principles for design and integration of safety-related parts of control systems
IEC 60825-1:2014	Safety of laser products - Part 1: Equipment classification and requirements
IEC 61000-6-2:2019	Electromagnetic compatibility ( EMC ) - Part 6-2: Generic standards – Immunity standard for industrial environments
ISO 11553-1:2020	Safety of machinery – Laser processing machines - Part 1: General safety requirements ( ISO 11553-1:2020 )
IEC 60204-1:2018	Safety of machinery – Electrical equipment of machines - Part 1: General requirements

## Further Reference to the harmonized standards in accordance with article 7 (2):

IEC 60825-4:2012-01-01	Safety of laser products - Part 4: Laser guards
------------------------	---

Markdorf, 15. June 2023

Place, Date



J.A. Jochen Huber  
Electrical engineering

## SpeedMarker 1600 (8095)



### Laser

Wavelength	1.064 nm
Laser source	Pulsed Yb-fiberlaser
Power stability	better $\pm 5\%$
Cooling	active fan cooled

Laser type	20W Fiber	20W MOPA	30W Fiber	50W Fiber	100W MOPA	
Maximum laser power	20W	20W	30W	50W	100W	
Pulse frequency (kHz)	1-600	1-4000	1-600	2-200	1-4000	
Pulse length(ns)	200	2-500	200	200	2-500	
Beam quality	$M^2 < 1.5$	$M^2 < 1.4$	$M^2 < 1.8$	$M^2 < 1.4$	$M^2 < 1.6$	
Maximum pulse energy [mJ]	0.8	0.8	0.8	1.25	1.5	

### Galvo System

Lens	F100	F160	F210	F254	F330	F420
Marking field XxY(mm)	70x70	120x120	150x150	190x190	240x240	310x310
Spotdiameter @ working dist.(mm)	0.027	0.045	0.059	0.068	0.088	0.112
Marking resolution (mm)	0.001	0.002	0.002	0.003	0.004	0.005
Max. marking speed (m/sec)	7	12	12	12	12	12

### Workstation with software-controlled X-, Y- and Z-axis

Lens	F100	F160	F210	F254	F330	F420
Maximum part height (mm)	485	424	367	317	247	137
Max. working area [WxD] (mm)	1180 x 420	1230 x 450	1260 x 450	1300 x 450	1300 x 450	1300 x 450
Maximum load	50 kg					
Working table	T-slot plate (Isel PT 25): 1300 x 450 mm					
Weight approx.	500 kg					

## System specification

Norm	CDRH Lasersafety; Laserclass 2; CE [EN 60825-1]
Dimensions [W x H x D in mm]	1600 x 2118 x 1179
Software	Speedmark; Directmark Printerdriver
Axis	software controlled
Supported mono fonts	ISOCT, RomanS, SOKOL
Supported fonts	all installed TrueTypeFonts
Supported 1D barcodes	Australian Post; Codebar; Code 11; Code 128; Code 39; Code 93; DAFT; Deutsche Post; DPD; EAN-13; EAN-14; EAN-8; GS1; HIBC; ISBN; GS1; Pharmacode
Supported 2D codes	Datamatrix; QR-Code; Aztec; Codeblock-F; GS1 Databar; HIBC; Maxi Code; PDF 417
Supported image formats	BMP; JPG; DXF; PDF; EPS; PS; TSF; DWG
Focus and pilot laser	Diode laser $\lambda = 655\text{nm}$ , Laser class 2; 1mW
Interfaces	Ethernet, RS232, Laser-Interlock, Marking-Start (24 VDC), Marking-Stop (24 VDC), E-Stop, Error-Reset, Laser-Busy, assignable digital I/O's (4/4; 24 VDC), USB, Ethernet, RS232
HMI	Integrated industrial PC as 19" unit 2RU Windows® 10, keyboard, mouse
Door	Manual/automatic door
Color	RAL 3002, RAL 7016, RAL 7035
Power supply	230 VAC, 16 A, 50/60 Hz, 1/N/PE
Maximum power consumption	1400 W
Cooling	active fan cooled
Protection level	Marking head: IP54 / rack unit: IP20
Mini. required exhaust	Atmos Nano

## Ambient conditions

Operation	Temperature range +15 to +35° C; Relative humidity max. 60 %. Non-condensing
Storage	Temperature range +0 to +30° C; Relative humidity max. 60 %. Non-condensing
Transport	Temperature range -10 to +40° C; Relative humidity max. 70 %. Non-condensing

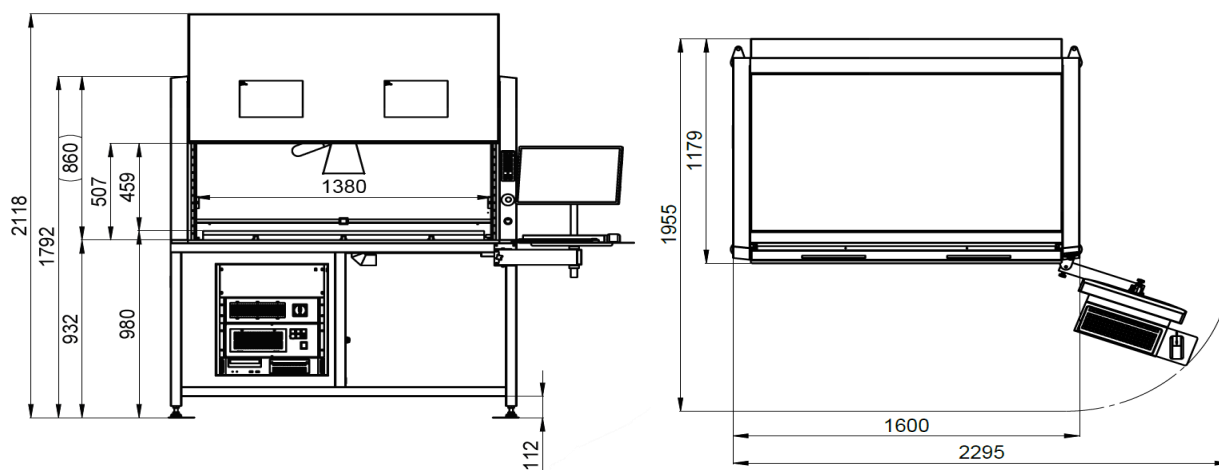

Tolerances on Dimensions: 1%

Content subject to change without prior notice.

v2.0 04/04/2023

→ **SpeedMark Vision - Smart Adjust Technical Datasheet**



→ **SpeedMark Vision – Smart Adjust**  
Integrated camera system for user friendly and precise positioning of markings directly on the product. Camera image is shown directly in the GUI of the laser software

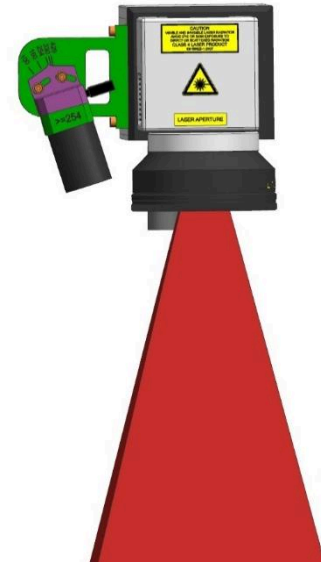

**Camera und Lens**

Sensor type	CMOS
Interface	USB 2.0
Optical class	1/2 "
Resolution class	10,55 MPixel
Camera resolution	3840 x 2748 Pixel
Pixel size	1.67 µm
Lens type	C-Mount
Focal length of camera lens	f = 8,5 mm; 12 mm; 25 mm

**Compatibility / Accessories**

Available for following products	SpeedMarker 300, 700, 1300, FL (OEM)
Software	SpeedMark 3.6
Camera package without lens	Material number: 98778 (Retrofit kit: 98781)
Lenses	<ul style="list-style-type: none"> <li>• f = 8,5 mm: Material number: 98777</li> <li>• <b>f = 12 mm: Material number: 92385 (default)</b></li> <li>• f = 25 mm: Material number: 92386 (precision)</li> </ul>



**Size of camera image (depending on lens)**

F-Theta lens laser	F-100	F-160	F-254	F-330	F-420
Marking field laser [mm]	70 x 70	120 x 120	190 x 190	240 x 240	310 x 310
8,5 mm lens [mm]	~ 140 x 100	~ 188 x 135	~ 290 x 208	~ 317 x 247	~ 432 x 309
<b>12 mm lens [mm] (default)</b>	<b>~ 87 x 62</b>	<b>~ 116 x 73</b>	<b>~ 187 x 134</b>	<b>~ 218 x 160</b>	<b>~ 257 x 195</b>
25 mm lens [mm] (precision)	~ 34 x 24	~ 50 x 37	~ 90 x 65	~ 113 x 80	~ 138 x 100

**Resolution depending on camera lens**

F-Theta lens laser	F-100	F-160	F-254	F-330	F-420
8,5 mm lens	27 Pixel/mm	20 Pixel/mm	13 Pixel/mm	11 Pixel/mm	9 Pixel/mm
<b>12 mm lens (default)</b>	<b>43 Pixel/mm</b>	<b>33 Pixel/mm</b>	<b>20 Pixel/mm</b>	<b>17 Pixel/mm</b>	<b>14 Pixel/mm</b>
25 mm lens (precision)	112 Pixel/mm	75 Pixel/mm	41 Pixel/mm	33 Pixel/mm	27 Pixel/mm

